

UNLIMITED WORLDS



LA COLLEZIONE '23



La collezione Frascio si presenta con sette proposte studiate per scoprire i nuovi orizzonti degli spazi e dell'architettura. Sette proposte che si differenziano per stili e finiture, pronte a rispondere alle nuove esigenze dell'abitare.

Scopriremo soluzioni dall'aspetto rude, come quello di un'officina, e altre che guardano al vintage, tanto in voga nell'arredo di oggi, riprendendo un classico originale Frascio degli anni 70, arrivando alle proposte che richiamano il design funzionalista per poi approdare ad una versione inedita che fa dell'empatia formale la sua cifra chiave.

Frascio un modo per scoprire mondi senza limiti.

The Frascio collection presents seven new designs to discover the new horizons of space and architecture. Seven designs that differ in style and finish, ready to respond to the new needs of living.

We will discover raw looking solutions, such as that of a workshop, and others with a vintage style, so popular in today's furniture, taking up an original classic Frascio design from the 70s, arriving at the proposals that recall functional design and then arriving at an unprecedented version that makes formal empathy its key figure.

Frascio is a way to discover a world without boundaries.



SEPPIA
BCF design

Da una forma ispirata all'osso di seppia nasce una maniglia dal carattere empatico, dove la forma arrotondata della presa sembra veleggiare sul collo della maniglia. Una fisionomia che vive sul colore e sulle finiture più raffinate.

From a shape inspired by a cuttlefish bone comes a handle with an empathic character, where the rounded shape of the socket seems to sail on the neck of the handle. A feature that lives on the most refined colors and finishes.



Marcello Cutino designer
 Si diploma al Politecnico di Milano in Industrial design. Fonda nel 1980 lo studio BCF, realtà composta da tre settori: design, comunicazione d'impresa, immagine. Ha ricevuto numerosi riconoscimenti nazionali e internazionali (Design Index, menzione d'onore al Compasso d'Oro e nomination al premio spagnolo Delta). Negli oltre quarant'anni di attività ha maturato un'importante expertise nei settori dell'arredo bagno e cucina.



Marcello Cutino designer
 He graduated from the Politecnico di Milano in Industrial design. In 1980 he founded the BCF studio, a reality composed of three sectors: design, business communication and image. He has received numerous national and international awards (Design Index, honorable mention at the Compasso d'Oro and nomination for the Spanish Delta award). In the last forty years of trading they have gained important expertise in the bathroom and kitchen furnishing sectors.

GRIGIO LUCIDO
GREY GLOSS



BIANCO LUCIDO
WHITE GLOSS



NERO OPACO
MATT BLACK



INOXCHROME



LONDON NIGHT SATINATO
LONDON NIGHT SATIN

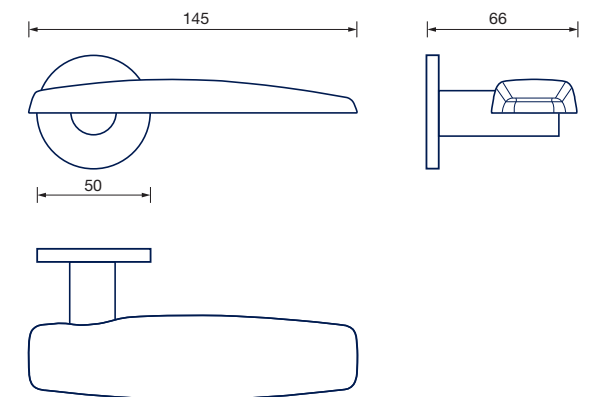

UNLIMITED WORLDS



BLU LUCIDO
BLUE GLOSS



ROSSO LUCIDO
RED GLOSS



VERDE LUCIDO
GREEN GLOSS



OTTANIO LUCIDO
TEAL GLOSS



ARANCIONE LUCIDO
ORANGE GLOSS



GIALLO LUCIDO
YELLOW GLOSS

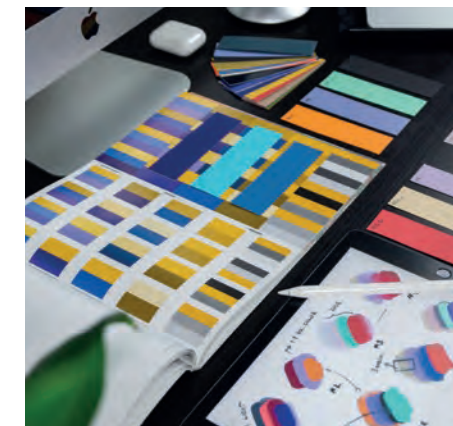

Con un costo aggiuntivo, è possibile personalizzare la maniglia SEPPIA con un colore a campione.

With an additional cost, you can customise the SEPPIA handle with any sample color.

UNLIMITED WORLDS



DECIMA
design Brian Sironi

DECIMA dal numero di maniglie progettate con il designer Brian Sironi. Una maniglia moderna: un archetipo attualizzato dall'aggiunta frontale di un "morbido" rigonfiamento ergonomico, sia fisico che cognitivo.

The 10th handle designed for Frascio by designer Brian Sironi. A modern handle: an original design updated by the addition of a "soft" ergonomic bulge, both physical and cognitive.



Nato a Seregno (MI) nel 1977, si laurea in Design al Politecnico di Milano e prosegue la sua formazione collaborando con architetti e designer. Il percorso formativo si colloca nel cuore della Brianza, a metà tra artigianale e accademico, con un radicamento sul territorio, parte integrante del suo progetto di designer italiano e cosmopolita. Nel gennaio del 2008 fonda il suo studio.

Photo Credits © Benvenuto Saba

Born in Seregno (MI) in 1977, he graduated in Design at the Milan Polytechnic and continued his education by working with architects and designers. His educational path took place in the heart of Brianza, a mix between the artisanal and the academic, with strong roots to the territory, an integral part of his projects as an Italian and cosmopolitan designer. In January 2008 he founded his own studio.

CROMO LUCIDO
POLISHED CHROME



CROMO SATINATO
SATIN CHROME



OTTONE SATINATO VERNICIATO
SATIN BRASS



NICKEL SATINATO VERNICIATO
SATIN NICKEL



NERO OPACO
MATT BLACK



BRONZO TREND
BRONZE TREND



ANTICO OPACO
MATT ANTIQUE BRASS

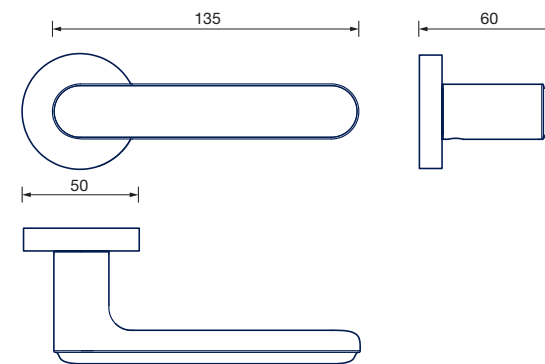



SIGMA
archivio FRASCIO 1978
arch. Lorenzo Rosa Fauzza

Un classico del design anni '70 di Frascio disegnato dall'architetto Lorenzo Rosa Fauzza. Stupisce per la sua eleganza, vero riferimento di un modello del passato più che mai in sintonia con le attuali tendenze dell'arredo.

A classic, from Frascio's 1970s design collection, designed by architect Lorenzo Rosa Fauzza. It's elegance amazes, a true reference of a model of the past more than ever in tune with current furnishing trends.



L'architetto Lorenzo Rosa Fauzza (1923-2008) nacque in Friuli a Maniago, in provincia di Pordenone. Studiò a Firenze e a Venezia, dove si laureò nel 1950 con una tesi in urbanistica sull'esperienza della ricostruzione tedesca, frutto di un periodo di apprendistato a Londra e in Germania. A Venezia, per tramite di Carlo Scarpa, ebbe modo di conoscere F.L.Wright nel corso di un suo viaggio in Italia. Nel '56 intraprende un'esperienza lavorativa a Colonia presso lo studio dell'architetto Fritz Ruempler. Dopo il rientro a Verona, dove aveva iniziato la libera professione già nel '52, proseguì una intensa attività, non solo in Veneto e nel Friuli ma in tutta Italia e all'estero (tra cui in Egitto, Grecia, Brasile e Thailandia). Amante delle opere lecorbusieriane e dei lavori di Alvar Aalto, ricercò un'architettura essenziale, lineare ed esente da sovrastrutture.

The architect Lorenzo Rosa Fauzza (1923-2008) was born in Friuli in Maniago, in the province of Pordenone. He studied in Florence and Venice, where he graduated in 1950 with a thesis in urban planning on the experience of German reconstruction, the result of an apprenticeship in London and Germany. In Venice, through Carlo Scarpa, he got to know F.L.Wright during his trip to Italy. In 1956 he began a work experience in Cologne at the studio of architect Fritz Ruempler. After returning to Verona, where he had started his freelance profession in 1952, he continued an intense activity, not only in Veneto and Friuli but throughout Italy and abroad (including Egypt, Greece, Brazil and Thailand). A lover of LeCorbusier's works and the works of Alvar Aalto, he sought an essential architecture, linear and free from superstructures.

Frascio®

CROMO LUCIDO
POLISHED CHROME



CROMO SATINATO
SATIN CHROME



OTTONE SATINATO VERNICIATO
SATIN BRASS



NICKEL SATINATO VERNICIATO
SATIN NICKEL



NERO OPACO
MATT BLACK



BRONZO TREND
BRONZE TREND



ANTICO OPACO
MATT ANTIQUE BRASS

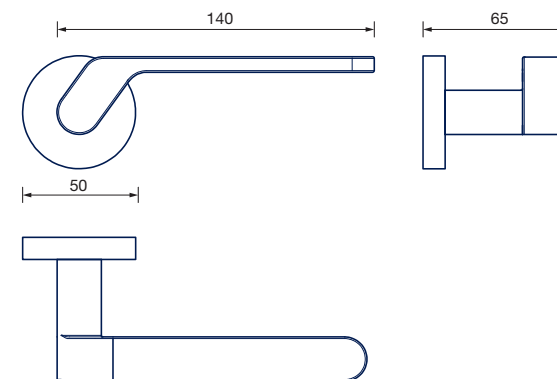

UNLIMITED WORLDS

Lo stile officina legato al design di questa maniglia ricorda la presa di una chiusura tecnica, rendendola particolarmente adatta agli ambienti che si ispirano a spazi ricavati da vecchie strutture industriali e commerciali, quali i loft. Uno stile particolarmente in voga nelle metropoli, dove i nuovi insediamenti architettonici subentrano alle vecchie aree industriali.

The workshop style linked to the design of this handle recalls the grip of a technical closure, making it particularly suitable for environments that are inspired by spaces obtained from old industrial and commercial structures, such as lofts. A style particularly in vogue in the metropolis, where the new architectural settlements take over from the old industrial areas.

DROP
design Massimo Facchinetti



Massimo Facchinetti si è laureato nel 1992 presso la Facoltà di architettura del Politecnico di Milano di cui ora è professore. Esercita la professione di architetto e designer occupandosi di importanti lavori pubblici in Italia e all'estero, tenendo in considerazione aspetti fondamentali della progettazione come il Design For All nell'ambito dell'Agenda 2030 e dei 17 punti dell'ONU nell'ecosostenibilità.

Massimo Facchinetti graduated in 1992 in Architecture at the Politecnico of Milan where he is now a professor. He practices the profession of architect and designer dealing with important public works in Italy and abroad, taking into consideration fundamental aspects of design such as Design For All within the 2030 Agenda and the 17 ONU points in eco-sustainability.

BIANCO OPACO
MATT WHITE



NERO OPACO
MATT BLACK



CROMO SATINATO
SATIN CHROME



BIANCO OPACO
MATT WHITE



NERO OPACO
MATT BLACK



CROMO SATINATO
SATIN CHROME

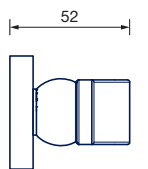
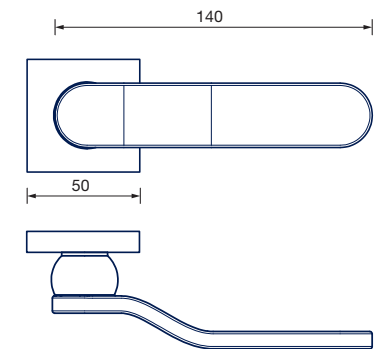
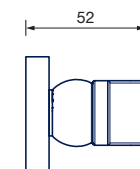
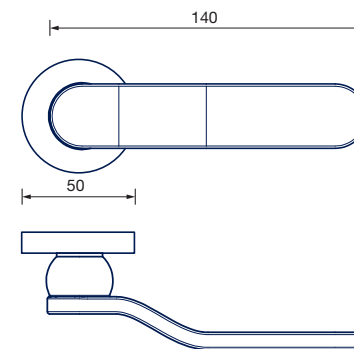



ZOE
FRASCIO design

La maniglia dallo spirito versatile,
una linea che si abbina in modo
efficace in tutte le situazioni,
elegante e funzionale al tempo
stesso.

The handle with a versatile spirit,
a design that works effectively in all
situations, elegant and functional
at the same time.



Frascio®

CROMO LUCIDO
POLISHED CHROME



CROMO SATINATO
SATIN CHROME



OTTONE SATINATO
SATIN BRASS



NERO OPACO
MATT BLACK



BRONZO TREND
BRONZE TREND



ANTICO OPACO
MATT ANTIQUE BRASS



CROMO LUCIDO
POLISHED CHROME



CROMO SATINATO
SATIN CHROME



OTTONE SATINATO
SATIN BRASS



NERO OPACO
MATT BLACK



BRONZO TREND
BRONZE TREND



ANTICO OPACO
MATT ANTIQUE BRASS

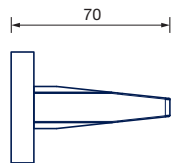
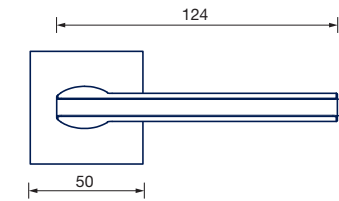
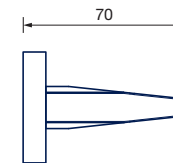
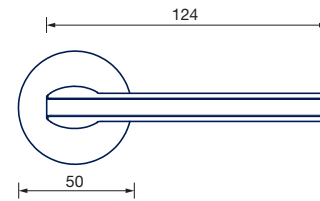



FORM
FRASCIO design

Lo stile di questa maniglia ricorda le ricerche del funzionalismo degli anni '30 e del design nato dal Bauhaus, uno stile più che mai attuale ripreso nelle architetture più importanti che dettano i moderni skyline delle metropoli.

The style of this handle recalls the theory that all aspects of society serve a function. A 1930s design created from the Bauhaus, a style more than ever current, specified in the most important architectures that dictate the modern skylines of the busiest cities!

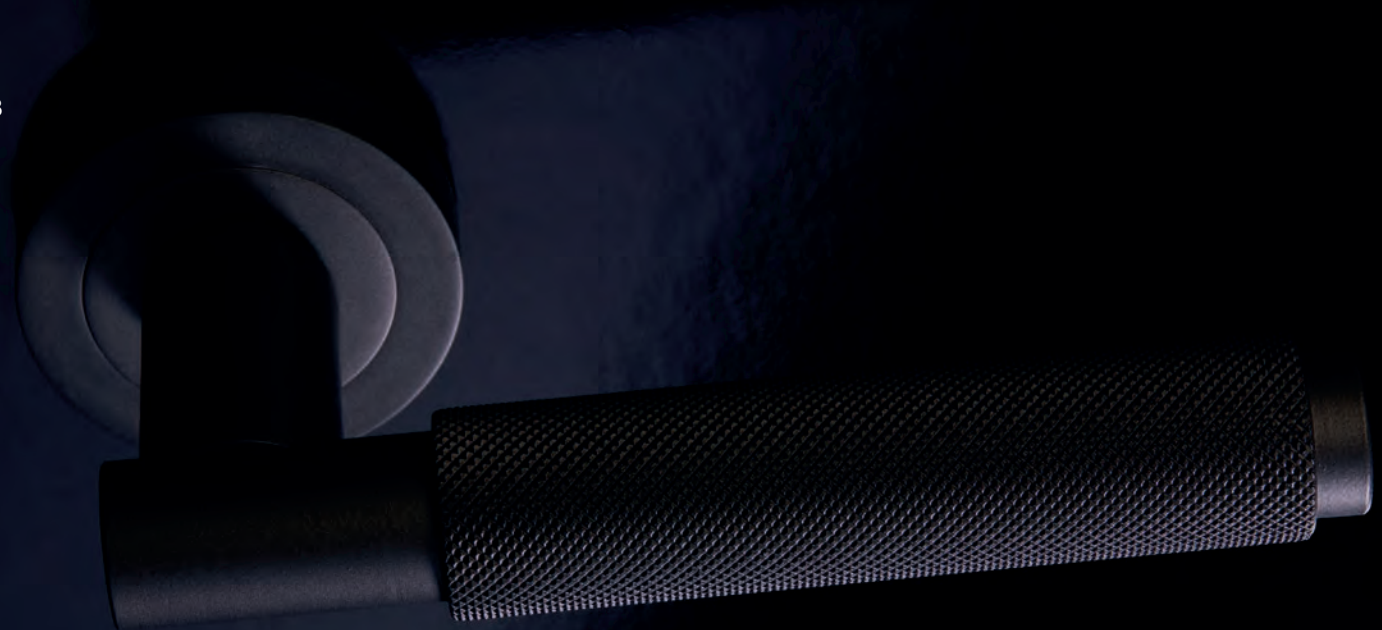

NERO OPACO
MATT BLACK



OTTONE SATINATO
SATIN BRASS



NICKEL SATINATO
SATIN NICKEL



ANTICO OPACO
ANTIQU MATT BRONZE



BRONZO TREND
BRONZE TREND

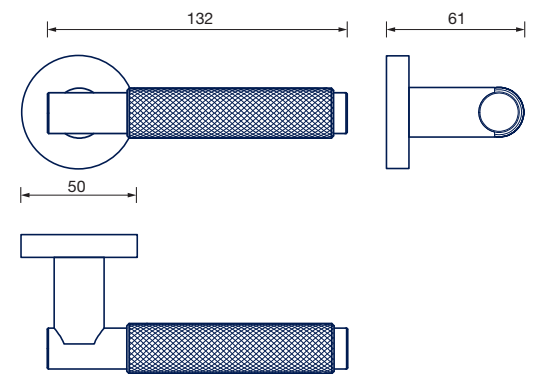



TECKNE
FRASCIO design

La maniglia ispirata al razionalismo architettonico. Forme quadrate si contrappongono a volumi cilindrici mettendo in evidenza lo stile classico e moderno allo stesso tempo.

The handle inspired by architectural rationalism. Square shapes contrast with cylindrical volumes highlighting the classic and modern style at the same time.

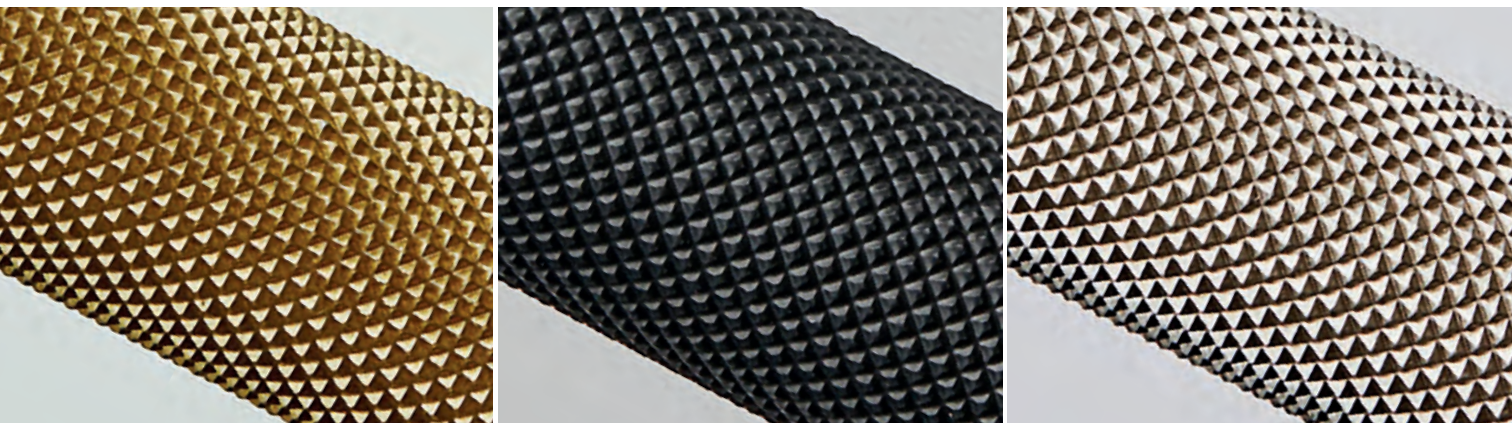

OTTONE SATINATO
SATIN BRASS



NERO OPACO
MATT BLACK



NICKEL SATINATO
SATIN NICKEL

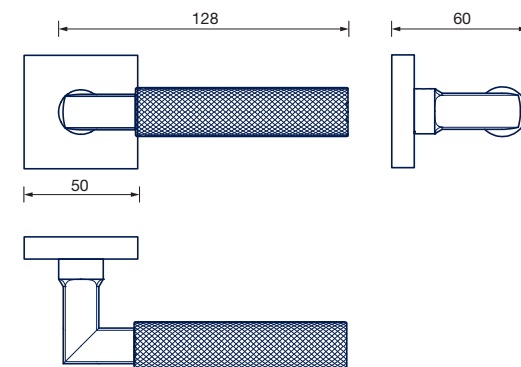



FRASCIO NEL MONDO

L'azienda è in grado di soddisfare con professionalità le richieste provenienti dal mondo mettendo a disposizione standard tecnici appropriati e soluzioni che rispondono alle effettive esigenze del mercato di riferimento. Le referenze delle opere architettoniche, nelle quali ogni anno vengono inserite le maniglie e i sistemi di apertura Frascio, testimoniano l'affidabilità di una fornitura e di un servizio attento alle necessità più esigenti.

FRASCIO IN THE WORLD

Frascio proudly offers its professional design range to satisfy demands from all over the world, providing technical standards, finishes, and design solutions that meet the needs of the local market. The presence of Frascio's handles in architectural works, that every year grows larger and larger, are proof of a reliability and a service that can comply even with the most demanding requests.

Frascio nasce nel 1945 come laboratorio artigianale.

Cresce costantemente negli anni seguendo un percorso orientato sullo sviluppo e la ricerca nel **settore dei complementi e degli accessori per porte e finestre**, fino a raggiungere il mercato internazionale.

Il continuo **aggiornamento nel campo del design** e l'**interesse verso le ultime innovazioni**, con una particolare attenzione sulle tecniche di lavorazione, l'utilizzo di materiali ecologici e nuove finiture, rende Frascio una realtà sempre in grado di rinnovarsi e di raggiungere "mondi illimitati". Frascio è la scelta ideale per entrare nel futuro ed esplorare *Unlimited Worlds*.

Frascio was founded in 1945 as an artisanal laboratory.

It has steadily grown over the years following a path towards development and research in the **sector of complements and accessories for doors and windows**, reaching the international market. **The constant updates in its designs** and **its interest in the latest innovations**, with particular attention to the manufacturing techniques and to the use of ecological materials and new finishes, makes Frascio a reality always able to renew itself and reach "unlimited worlds". Frascio is the ideal choice to enter into the future and explore *Unlimited Worlds*.

UNLIMITED WORLDS

frascio®

FRASCIO S.r.l.

Via Nazionale 6 - 25074 Lavenone (BS) - Italy
Tel. +39 0365 839001 - Fax. +39 0365 83578
e-mail: info@frascio.it - www.frascio.it