

Pibamarmi



Pibamari

IL PROGETTO PIBAMARMI

PIBAMARMI PROJECT

“Creatività nel segno della naturalità.”
è l’assioma attorno al quale Pibamarmi
costruisce il suo percorso di innovazione.
La pietra, rispettata e valorizzata nelle sue
qualità strutturali ed estetiche più semplici
e vere, intesa come elemento terrestre
e primigenio, è così di volta in volta ripensata
in funzione di una relazione diretta con gli altri
elementi della natura: l’aria, l’acqua, la luce.

“Creativity hallmarked by naturality.”
It is the axiom on which the company
has built its innovation path; stone, respected
and valorised in its simplest and most genuine
structural and aesthetical qualities, and meant
as a primeval and terrestrial element, is
re-thought each time in function of its direct
relationship with other natural elements:
air, water, and light.



Contenuti Contents

- 6 VISIONE**
VISION
- 8 PRODUZIONE**
PRODUCTION
- 10 INNOVAZIONE ACID SHIELD**
ACID SHIELD INNOVATION
- 12 INTERNI**
INTERIORS
- 28 COMPLEMENTI E OGGETTI**
COMPLEMENTS AND OBJECTS
- 46 COLLEZIONI**
COLLECTIONS
- 48 DESCO**
- 58 PIANO DI POSA**
- 66 THE BLACK BROTHERS**
- 72 STONE LIKES WATER**
- 84 ESCAVO**
- 94 SATURNIA**
- 102 PLAY**
- 110 BASIC COLLECTION**
- 124 MATERIALI**
MATERIALS
- 126 PIETRE E MARMI NATURALI**
NATURAL MARBLES AND STONES
- 136 SUPERFICI**
SURFACES
- 146 MOSAICI**
MOSAICS
- 148 FORMATI E DIMENSIONI**
FORMATS AND SIZES
- 149 GUIDA ALLA POSA**
GUIDE TO LAYING
- 150 PULIZIA E MANUTENZIONE**
CLEANING AND MAINTENANCE

BRIGHT CLOISTER

Go Hasegawa, Padiglione
espositivo Pibamarmi, 2016.
Materiale Crstallino Hebron

VISIONE VISION

Pibamarmi inizia la sua attività nel 1967.

Oggi l'azienda interpreta i valori della contemporaneità promuovendo una radicale innovazione del prodotto in pietra naturale che si sviluppa in stretta sinergia con la più alta cultura internazionale di architettura e di design. Da tempo infatti il brand di Chiampo opera in collaborazione diretta con progettisti quali Michele De Lucchi, Manuel Aires Mateus, Alberto Campo Baeza, Eduardo Souto de Moura e Philippe Nigro, realizzando collezioni di elementi per l'ambiente bagno, di tavoli e sedute, di superfici architettoniche per pavimentazioni e rivestimenti. Tra il 2008 e il 2018 De Lucchi, Campo Baeza, Aires Mateus, Snøhetta, Grafton Architects e Go Hasegawa firmano per l'azienda progetti sperimentali di design espositivo in pietra, realizzati in occasione delle edizioni del Marmomacc di Verona e dei Saloni di Milano.

Pibamarmi started its activities back in 1967.

Today the company interprets the values of contemporary times promoting a radical innovation in the natural stone product, developed in strict synergy with the most refined international culture in architecture and design. For long time the brand from Chiampo has been working together with designers such as Michele De Lucchi, Manuel Aires Mateus, Alberto Campo Baeza, Eduardo Souto de Moura and Philippe Nigro to create collections of bathroom furnishing elements, of tables and seats, of architectural surfaces for floorings or coverings. Between 2008 and 2018 De Lucchi, Campo Baeza, Aires Mateus, Snøhetta, Grafton Architects and Go Hasegawa designed for the firm experimental projects of exhibit design, created for the Marmomacc editions in Verona and I Saloni in Milan.

LA PIETRA DI SISIFO

Alberto Campo Baeza,
Padiglione espositivo Pibamarmi,
2013. Materiali Bianco Carrara
e Travertino Noce

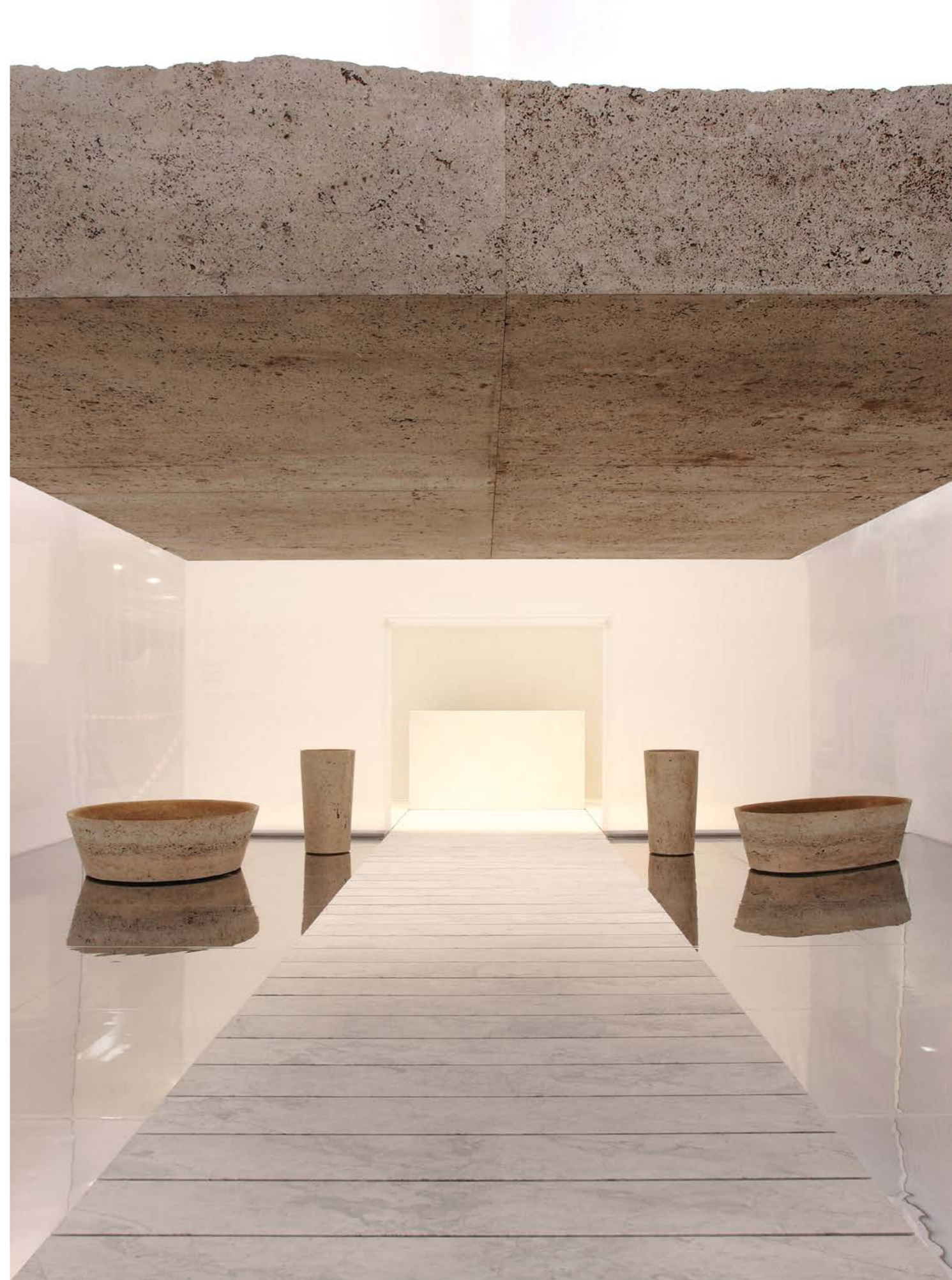

PRODUZIONE PRODUCTION

Pibamarmi affianca il committente e il progettista lungo tutto il ciclo di esecuzione dell'opera lapidea, dalla fornitura dei materiali, all'ingegnerizzazione del progetto, alla lavorazione del prodotto finito.

Configurata come una smart company agile e indipendente, l'azienda è forte della formazione tecnica e della solida esperienza dei suoi operatori. Il brand di Chiampo è così in grado di capitalizzare una propensione all'innovazione concreta, lontana dai concetti sorprendenti e mediatici di una certa contemporaneità e basata per contro sul saper ideare e saper fare, ottimizzando i processi e personalizzando i prodotti.

In avvio del terzo millennio, Pibamarmi si iscrive a pieno titolo nel sistema artigianale della tradizione italiana, ormai evoluto in una rete di autori post industriali, in grado di coniugare l'antica sensibilità nei confronti dei materiali, con un magistero creativo del tutto peculiare e con la capacità d'impiego e interpretazione delle tecnologie esecutive più avanzate.

Ogni prodotto di Pibamarmi è interamente realizzato in azienda, in un processo di costante controllo della qualità che si focalizza sulla materia prima lapidea, sulle lavorazioni, le finiture, l'imballaggio e le operazioni di spedizione.

Pibamarmi supports the clients and the architects throughout the entire processing of the stone work, from the supply of materials to the engineering of the project, till the manufacturing of the final product.

Configured as an independent and flexible smart company, the firm can rely on the technical training and solid experience of its employees. The brand from Chiampo capitalizes on its predisposition to substantial innovation, far from the mind-blowing tendency of contemporary media, but based on the expertise to conceive and create optimized processes and customized products.

At the beginning of the 3rd millennium, Pibamarmi is fully comprehended in the Italian traditional manufacturing system, that has become nowadays a network of post industrial makers, able to connect the ancient sensitivity toward materials to the most advanced technological interpretations and executions.

Each Pibamarmi product is created in its entirety within the company, in a process characterized by continuous quality control focused on the stone material, the manufacturing activity, the finishing, packing and shipping.

THE BURREN

Grafton Architects, Padiglione
espositivo Pibamarmi, 2012.
Materiale Nero Assoluto



INNOVAZIONE ACID SHIELD

ACID SHIELD INNOVATION



Acid Shield è il rivoluzionario trattamento protettivo messo a punto e applicato in proprio da Pibamarmi su tutti i tipi di manufatti in pietra o marmo.

Forma uno scudo invisibile contro acidi, coloranti e grassi. Senza alterare le qualità cromatiche naturali dei materiali lapidei, protegge da macchie, aloni, rigature e perdite di tonalità e brillantezza.

Acid Shield è certificato in base alle seguenti normative:

- UNI EN 12720 (resistenza ai liquidi)
- Regolamento 1935/04/CE (contatto con alimenti)
- DPR 777/82
- DM 29/2017

Acid Shield is a revolutionary protection for marbles and stones conceived by Pibamarmi against acids, colorants and grease.

It coats any material with an invisible satin-like shield without altering its natural chromatic aspects and protecting it from stains, etches and losses of brilliance and color.

Acid Shield is certified according to the following regulations:

- UNI EN 12720 (resistance to liquids)
- Regulation 1935/04/CE (contact with food)
- DPR 777/82
- DM 29/2017



INTERNI INTERIORS

PIETRA SENAPE

Rivestimento
in Pietra Senape,
finitura Random

Pietra Senape cladding,
Random surface



PIETRA SENAPE

Pavimento in Pietra Senape,
finitura Patinato

Floor in Pietra Senape,
Patinato surface



INTERNI INTERIORS

Pibamarmi realizza interni e allestimenti litici per il luxury living, gli spazi retail e il contract alberghiero. L'azienda affianca in questo caso architetti e designer di rilievo internazionale lungo tutto il ciclo di esecuzione dell'opera, dalla fornitura dei materiali, all'ingegnerizzazione del progetto, alla lavorazione dei pezzi su misura destinati all'esecuzione di pavimenti, scale, rivestimenti ed elementi di arredo.

Pibamarmi creates interiors and settings in stone for luxury living, retail spaces and hospitality contracts. The firm works together with internationally recognized architects and designers during the entire workflow, from the shipping of materials to the project engineering, from the customization of elements to the creation of floors, stairs, coverings and furnishing objects.



BIANCO CARRARA

Rivestimento in Bianco Carrara, finitura Seta Grezza

Bianco Carrara cladding, Seta Grezza surface

AMABILE

Lavabo in massello di Nero Marquinia

Carved wash basin in Nero Marquinia

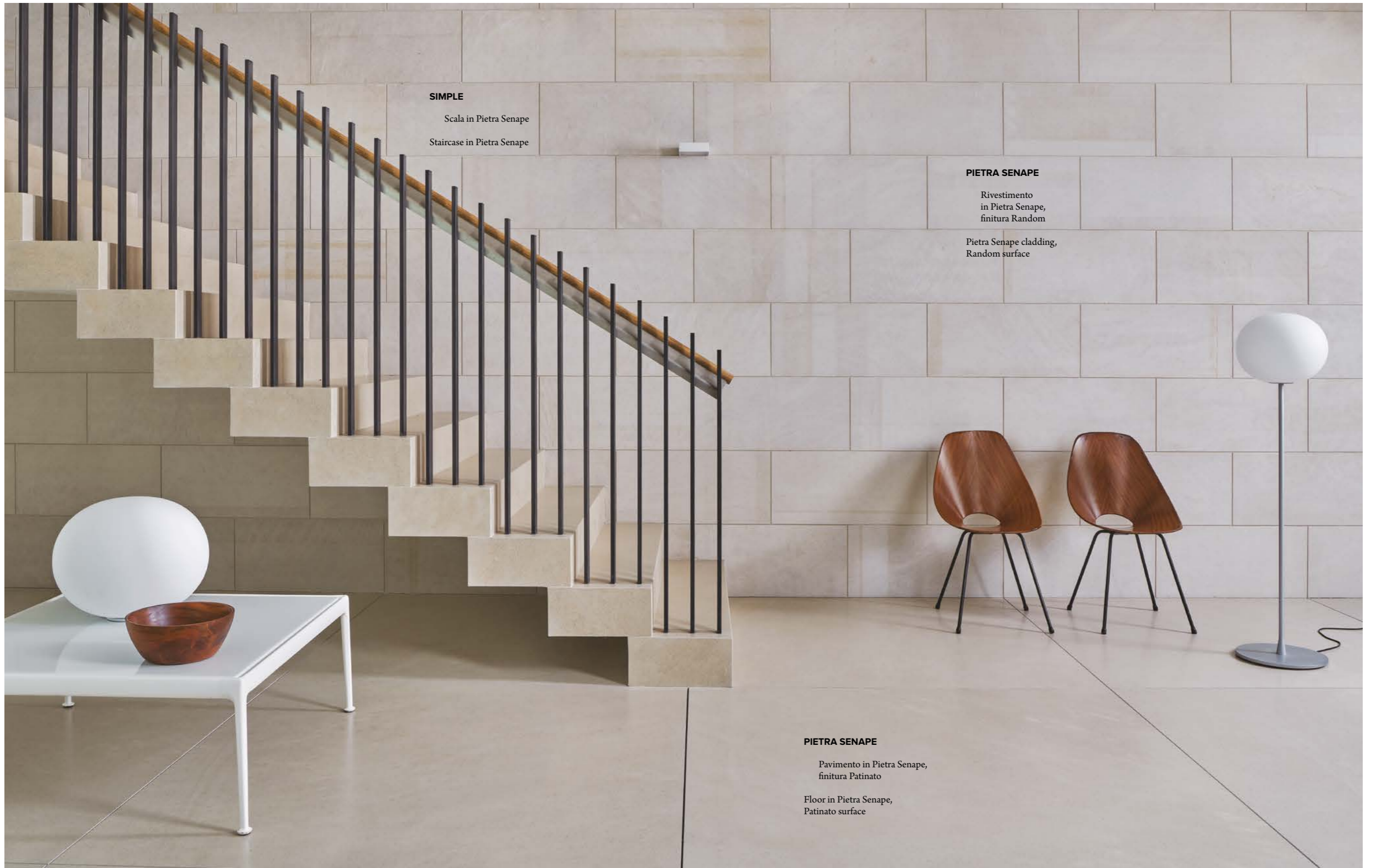

SIMPLE
Scala in Pietra Senape
Staircase in Pietra Senape

PIETRA SENAPE
Rivestimento
in Pietra Senape,
finitura Random

Pietra Senape cladding,
Random surface

PIETRA SENAPE
Pavimento in Pietra Senape,
finitura Patinato

Floor in Pietra Senape,
Patinato surface

BRONZE GRAY

Rivestimento in Bronze Gray,
finitura Slash

Bronze Gray cladding,
Slash surface



MARBLE KITCHEN

Lavello e rivestimento
in Nero Marquinia
con trattamento Acid Shield

Basin and cladding
in Nero Marquinia with
Acid Shield protection



CALACATTA ORO

Rivestimento in Calacatta
Oro, finitura Lucido

Calacatta Oro cladding,
Lucido surface

TRILITE

Design Daniele Della Porta

Tavolo in Nero Marquinia

Table in Nero Marquinia



AIRES

Rivestimento
in Pietra di Brera,
finitura Seta Grezza

Pietra di Brera cladding,
Seta Grezza surface

SIMPLE ELLIPSE

Vasca in massello
di Pietra di Brera

Carved bathtub
in Pietra di Brera





BOUTIQUE A MILANO
Design Claudio Silvestrin

Monoliti in scorze
di Pietra Senape

Raw skin blocks
in Pietra Senape





BOUTIQUE A AMSTERDAM
Design Claudio Pironi & Partners

Pavimenti e rivestimenti
in Grigio Portaluppi,
finitura Patinato

Floors and cladding in Grigio
Portaluppi, Patinato surface

COMPLEMENTI E OGGETTI

COMPLEMENTS AND OBJECTS

ZENONE

Design Stormo Studio

Lampada da tavolo
in Bianco Carrara

Table lamp in Bianco Carrara

NOVE DICHIOTTO

Design Filippo Protasoni

Oggetti da scrivania
in Bianco Carrara

Desk set in Bianco Carrara



COMPLEMENTI E OGGETTI

COMPLEMENTS AND OBJECTS

Arredi, complementi e oggetti d'uso in marmo o pietra naturale sono un punto di forza della produzione Pibamarmi, per un total design litico che consente di allestire in modo organico e flessibile tutti i contesti della vita contemporanea. Le apparenti limitazioni indotte dalla natura della pietra diventano stimoli per salvaguardare la funzionalità dei prodotti e per rendere pregevoli e originali le intuizioni formali e costruttive più elementari.

Furnishing elements, complements and objects in natural stone or marble are a keypoint of Pibamarmi production, in a total stone design that shape all the contexts of contemporary life in a homogeneous and flexible way. The apparent limitations of the stone material become a stimulating challenge to preserve the functionality of the products and to give value and originality to elementary intuitions.



APULEIO
*Design Michele De Lucchi,
Philippe Nigro*

Lampada a sospensione
in Bianco Carrara

Hanging lamp in Bianco Carrara



X TABLE

Design Omri Revesz

Tavolini con piani in marmo
e struttura metallica

Small tables with marble tops
and metal structure

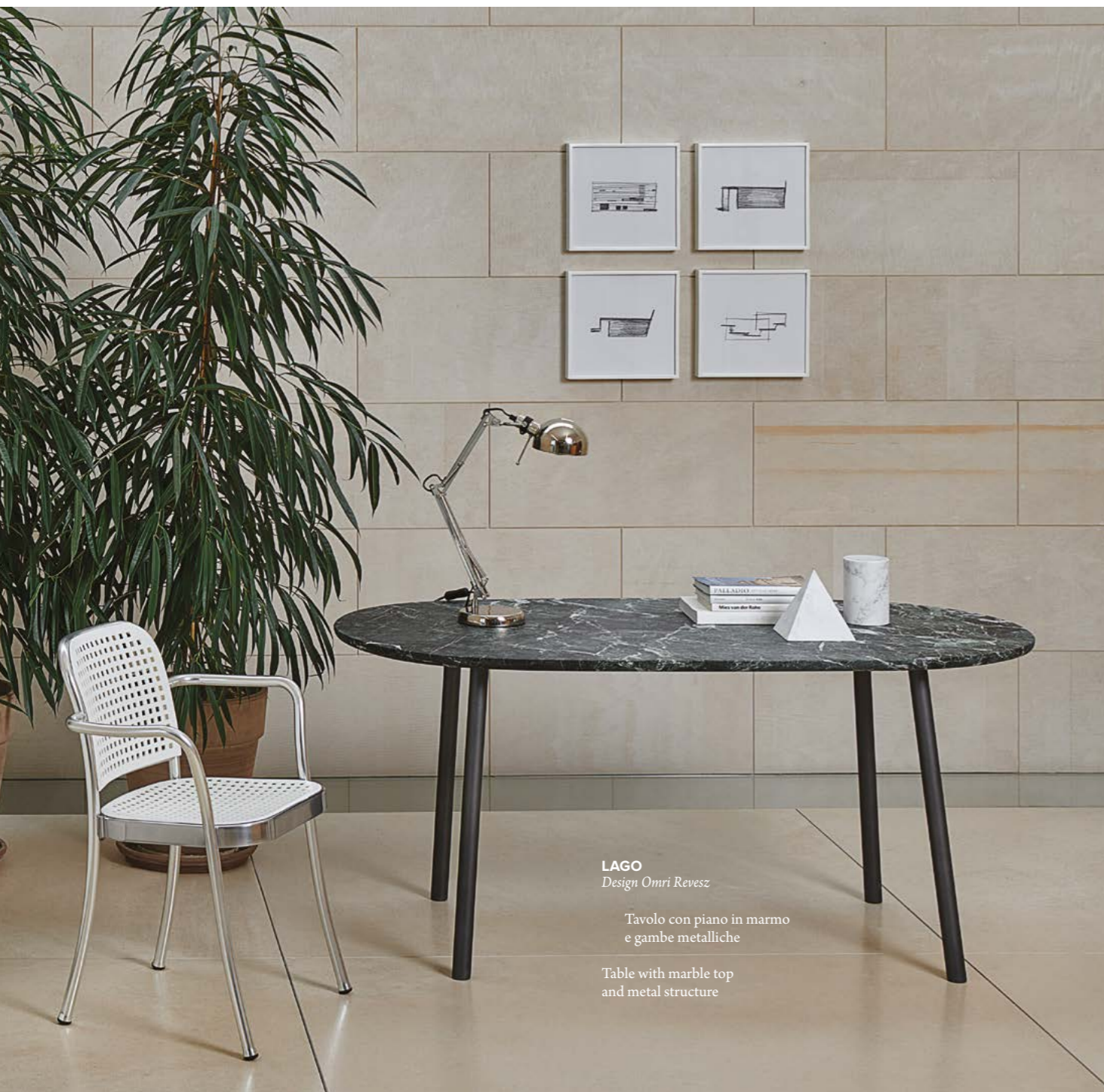

LAGO
Design Omri Revesz

Tavolo con piano in marmo
e gambe metalliche

Table with marble top
and metal structure



SKYLINE
Design Omri Revesz

Tavolini con piani in marmo
e struttura metallica

Small tables with marble tops
and metal structure

PALOMAR

Design Bom Design Studio

Lampade da tavolo
in Bianco Carrara
e Grigio Portaluppi

Table lamps in Bianco Carrara
and Grigio Portaluppi



NOVE DICOTTO

Design Filippo Protasoni

Oggetti da scrivania
in Bianco Carrara

Desk set in Bianco Carrara

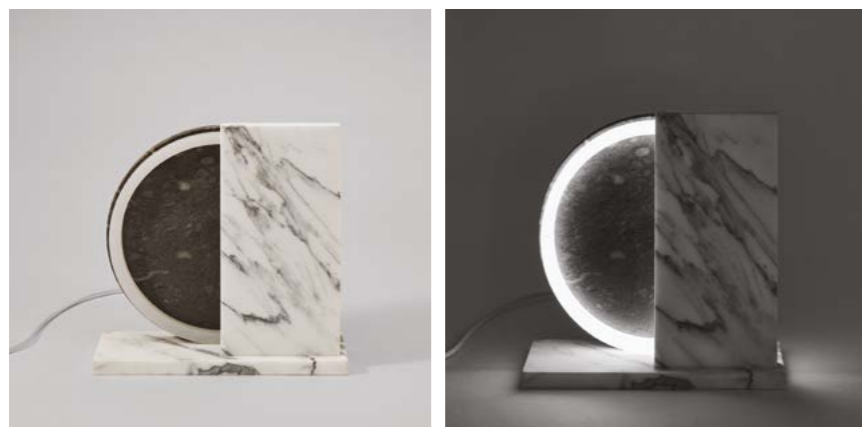



PROGETTO 58
Design Gianluca Gimini

Reggilibri e svuotatasche
in Grigio Bardiglio e ottone

Bookends and coin trays
in Grigio Bardiglio and brass



INTERNO MARMO

Design Studio Lievito

Candeliere, reggilibri
e contenitore componibile
in marmo

Candlestick, bookends
and modular marble container





ENHYDRO

Design Francesco Dell'Aglio

Lampada e candeliera
in marmo, onice e vetro

Lamp and candlestick in marble,
onyx and glass



IN BILICO

Design Daniele Della Porta

Vasi e vassoi in
Nero Marquinia e resina

Vases and trays in Nero Marquinia
and resin



TABLA BIANCA

Design Alberto Campo Baeza

Tavolo in Bianco Carrara
con struttura metallica

Bianco Carrara table
with metal structure



COLLEZIONI COLLECTIONS



ESCAVO

- Bacia
- Balde
- Balde colonna
- Banheira circolare
- Banheira ovale
- Plano



PIANO DI POSA

- | | |
|---------------------|-----------------------|
| Campiaro | Grizzana Servo Circle |
| Campiaro Griglia | Grizzana Servo Plain |
| Grizzana S | Grizzana Servo Square |
| Grizzana M | Grizzana Servo Tray |
| Grizzana L | |
| Grizzana Griglia 40 | |
| Grizzana Griglia 60 | |
| Grizzana Griglia 80 | |

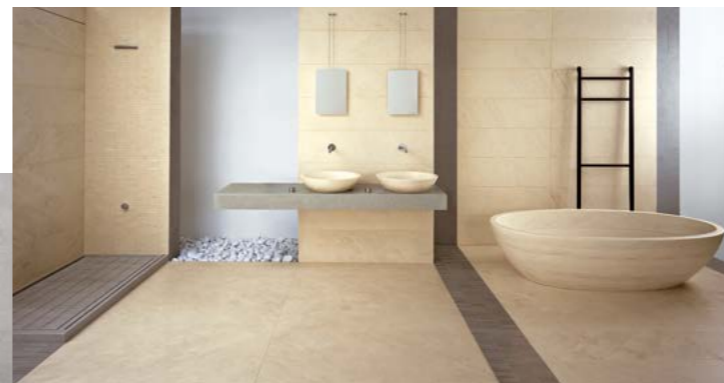

BASIC COLLECTION

- | | |
|-----------------|------------------|
| Barrique | Lugano |
| Catino | M45 |
| Citrohan | M45 + vanity top |
| Citrohan doppia | Minimal |
| Egg | Ozenfant |
| Fedaja | Slope |
| Fimon | Superpila |
| Idro Circle | Tabla con Catino |
| Idro Plank | Thin |
| Idro Ruler | Tinozza |
| Idro Strip | Wok |
| Jeanneret | |

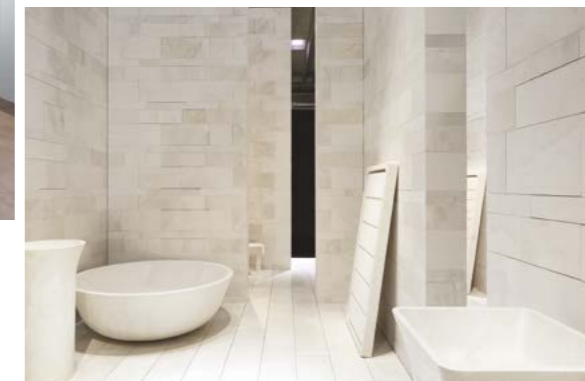

PLAY

- Easy / Circle
- Easy / Square
- Idro Soft
- Quick / Circle
- Quick / Square
- Simple Circle
- Simple Ellipse



THE BLACK BROTHERS

- Amabile
- Elegante
- Gentile
- Ruvido



STONE LIKES WATER

- Fukuoka
- Kobe esterna
- Kobe interna
- Kyoto
- Kyoto con Catino
- Nagoya
- Osaka
- Wabi



SATURNIA

- Basin
- Bath
- Box
- Column
- Double Basin
- Double Box
- Double Sink
- Saturnia Shower
- Sink



DESCO

- Big Desco
- Small Desco
- Desco Circle
- Desco Oval
- Desco Table
- Desco Servant
- Desco Box
- Desco Candlestick
- Desco Mirror

Gli oggetti sono disponibili in tutte le varietà dei materiali a catalogo

The items are available in all our materials

DESCO

design *Vittorio Longheu*



BIG DESCO

Lavabo in massello
di Nero Marquinia

Carved wash basin
in Nero Marquinia



DESCO CIRCLE

Vasca in massello
di Nero Marquinia

Carved bathtub
in Nero Marquinia



DESCO SERVANT

Tavolino in Nero Marquinia
Small table in Nero Marquinia



DESCO

design *Vittorio Longheu*

Big Desco
Small Desco
Desco Circle
Desco Oval
Desco Table
Desco Servant
Desco Box
Desco Candlestick
Desco Mirror

La collezione materializza nello spazio bagno, o nella camera da letto, un arcipelago di elementi litici fortemente caratterizzanti, contrassegnati da forme circolari e da minime asimmetrie dei volumi. Larghe tese attorno ai catini trasformano i lavabi in piccoli tavoli attorno a cui indugiare per compiere molteplici azioni. Complementi e oggetti in marmo e ottone sono frutto della più sapiente e raffinata artigianalità italiana.

For the bathroom or bedroom, Desco collection defines a peculiar set of elements, characterized by circular shapes and minimal asymmetries in the volumes. The large edges of the washbasins turn them into small tables you can indulge around while doing your everyday activities. Complements and design objects are the result of the finest and most sophisticated Italian handcraft tradition.

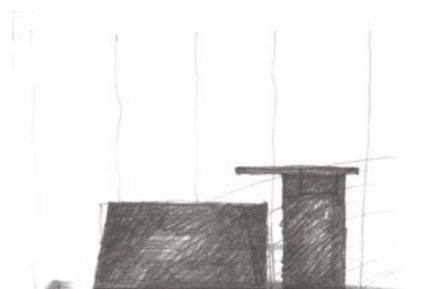

DESCO MIRROR

Specchio da tavolo
in Nero Marquinia e ottone

Table mirror in Nero Marquinia
and brass



DESCO BOX

Scatola in Nero Marquinia
e ottone

Box in Nero Marquinia
and brass



DESCO CANDLESTICK

Candeliere in Nero Marquinia
e ottone

Candlestick in Nero Marquinia
and brass



DESCO OVAL

Vasca in massello
di Nero Marquina

Carved bathtub
in Nero Marquina

SMALL DESCO

Lavabo in massello
di Nero Marquina

Carved basin
in Nero Marquina

DESCO TABLE

Tavolino in Nero Marquina
e ottone

Small table in Nero Marquina
and brass



TRAVERTINO MILANO

Rivestimento in Travertino
Milano, finitura Patinato

Travertino Milano cladding,
Patinato surface

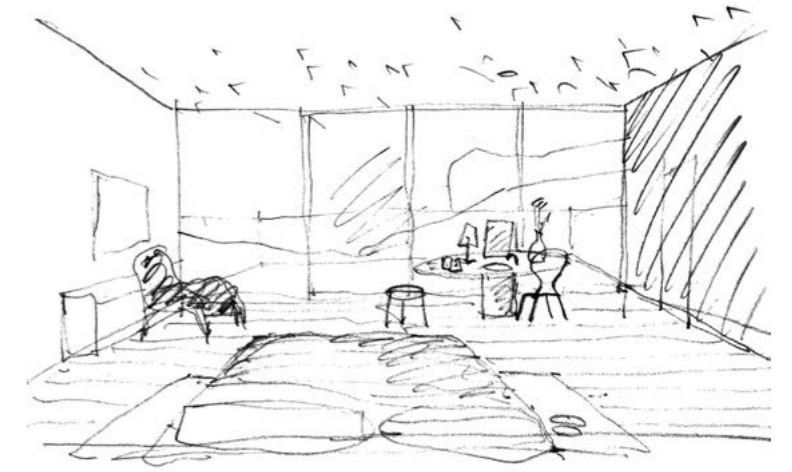

**DESCO CIRCLE
BIG DESCO**

Vasca e lavabo in massello
di Nero Marquinia

Carved bathtub and wash basin
in Nero Marquinia

INFORMAZIONI TECNICHE TECHNICAL INFORMATION

SMALL DESCO

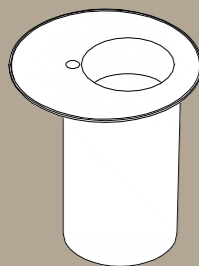

lavabo *wash basin*
Ø 70x75 cm
115 kg peso *weight*

BIG DESCO

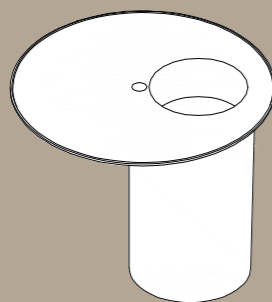

lavabo *wash basin*
Ø 90x75 cm
135 kg peso *weight*

DESCO SERVANT

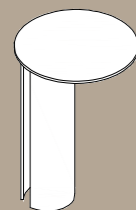

tavolino *small table*
Ø 45x61 cm
45 kg peso *weight*

DESCO TABLE

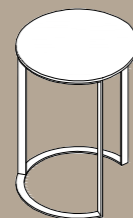

tavolino *small table*
Ø 45x61 cm
14 kg peso *weight*

DESCO MIRROR



specchio *mirror*
Ø 30 cm
9 kg peso *weight*

DESCO BOX



scatola *box*
Ø 15,5x15,5 cm
1,5 kg peso *weight*

DESCO CANDLESTICK



candeliere *candlestick*
Ø 14x8,5 cm
0,3 kg peso *weight*

DESCO OVAL

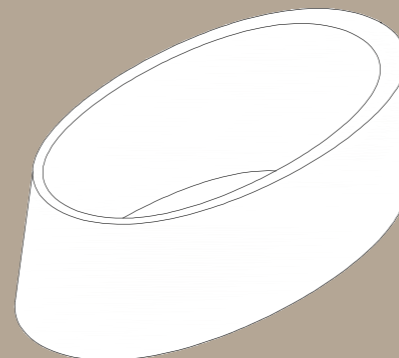

vasca *bathtub*
170x90x54 cm
superficie d'appoggio *leaning surface* 1,08 mq
350 kg peso *weight*
310 l capacità *capacity*

DESCO CIRCLE

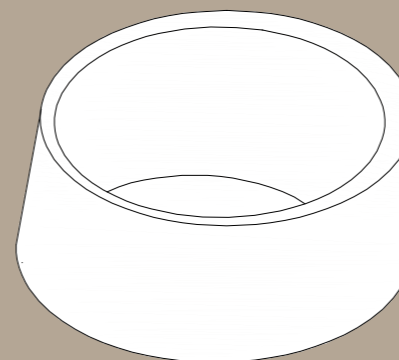

vasca *bathtub*
Ø 140x54 cm
superficie d'appoggio *leaning surface* 1,82 mq
560 kg peso *weight*
530 l capacità *capacity*

PIANO DI POSA

design *Vittorio Longheu*

BRONZE GRAY

Rivestimento
in Bronze Gray,
finitura Random

Bronze Gray cladding,
Random surface



GRIZZANA L

Lavabo in Nero Marquina
con griglia in legno
di rovere naturale

Wash basin
in Nero Marquina
with grid in natural oak



CAMPIARO

Piatto doccia
in Nero Marquina
con pedana in legno
di rovere naturale

Shower tray
in Nero Marquina with
footboard in natural oak

PIANO DI POSA

design *Vittorio Longheu*

Campiaro
Campiaro Griglia
Grizzana S
Grizzana M
Grizzana L
Grizzana Griglia 40
Grizzana Griglia 60
Grizzana Griglia 80
Grizzana Servo Circle
Grizzana Servo Plain
Grizzana Servo Square
Grizzana Servo Tray

La pittura di Giorgio Morandi si esprime attraverso oggetti elementari, collocati su piani di posa neutri, in luoghi vuoti ed astratti; si tratta di artefatti spesso accompagnati dalle loro sintesi geometriche, che nelle tele dell'artista vengono rivelati come entità immote e silenziose, e allo stesso tempo come presenze liriche ed evocative. A tali forme e a tali spazi mentali prima ancora che pittorici, si ispira questa collezione di lavabi e piatti doccia in legno e marmo; caratterizzata da forme lineari e assolute, disposte ad accogliere gli oggetti e i rituali della quotidianità ontemporanea.

Giorgio Morandi's painting style is expressed by elementary objects, laid on neuter surfaces, in abstract and empty spaces; these artefacts are often together with their geometrical synthesis, represented on the canvas as motionless silent entities and at the same time as lyrical and evocative presences. These shapes and spaces – mental before being pictorial – are the inspiration for this collection of washbasins and shower plates in marble and wood; absolutely linear forms, conceived to welcome the objects and rituals of contemporary everyday life, characterize the series.

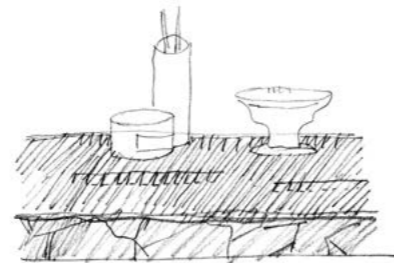

BRONZE GRAY

Rivestimento
in Bronze Gray,
finitura Random

Bronze Gray cladding,
Random surface



CAMPIARO

Piatto doccia
in Nero Marquinia
con pedana in legno
di rovere naturale

Shower tray in Nero Marquinia
with footboard in natural oak

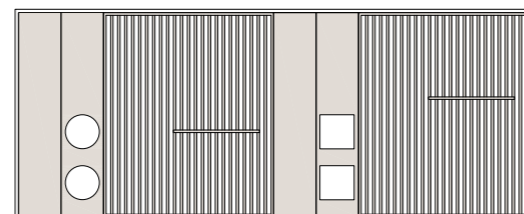
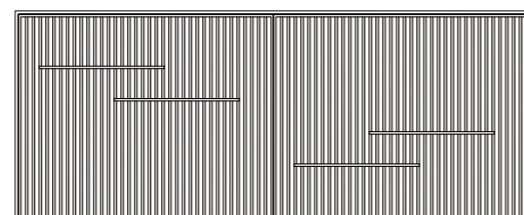
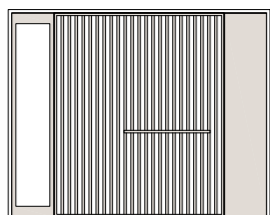
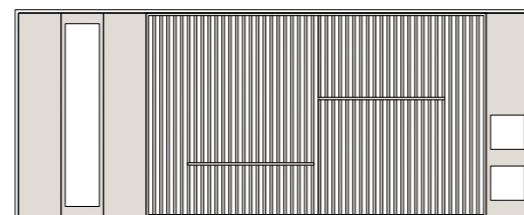
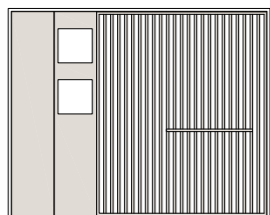
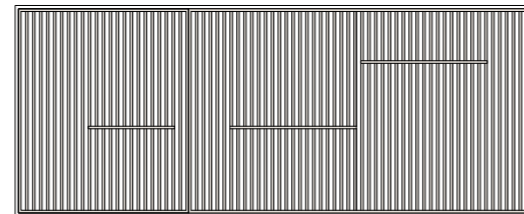

GRIZZANA S / M / L

Possibili composizioni
delle griglie e dei servi
in rovere naturale

Compositions of grids
and shelves in natural oak



GRIZZANA M

Lavabo in Nero Marquina
con griglia in legno
di rovere naturale

Wash basin in Nero Marquina
with grid in natural oak

INFORMAZIONI TECNICHE TECHNICAL INFORMATION

GRIZZANA S

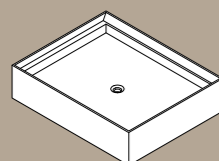

lavabo *wash basin*
61,6x49,6x15 cm
55 kg peso *weight*

GRIZZANA M

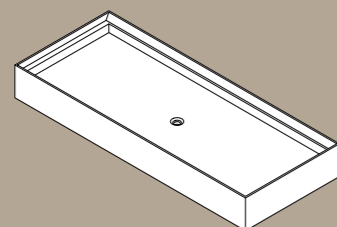

lavabo *wash basin*
121,6x49,6x15 cm
90 kg peso *weight*

GRIZZANA L

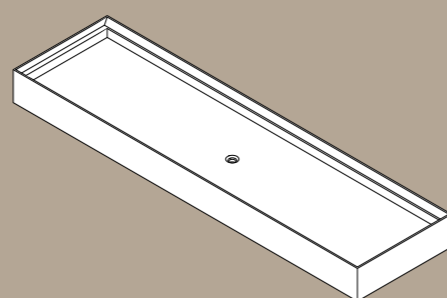

lavabo *wash basin*
181,6x49,6x15 cm
125 kg peso *weight*

CAMPIARO

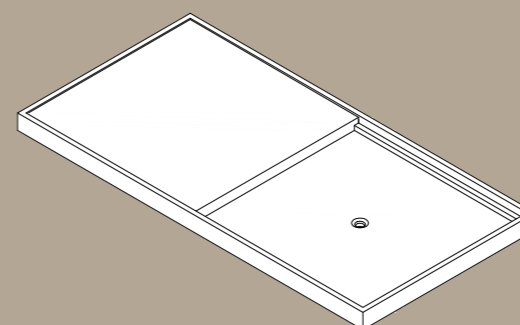

piatto doccia *shower tray*
160x80x8 cm
superficie d'appoggio
leaning surface 1,2 mq
160 kg peso *weight*

GRIZZANA GRIGLIA 40

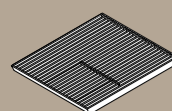

griglia *grid*
40x48x3 cm

GRIZZANA GRIGLIA 60

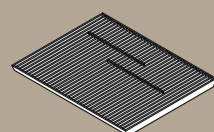

griglia *grid*
60x48x3 cm

GRIZZANA GRIGLIA 80

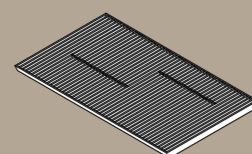

griglia *grid*
80x48x3 cm

CAMPIARO GRIGLIA

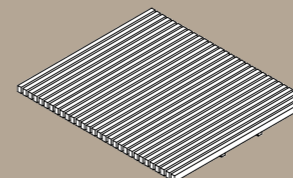

griglia *grid*
88,4x75,6x3 cm

GRIZZANA SERVO PLAIN

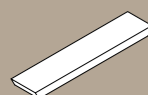

servo portaoggetti
shelf
10x48x3 cm

GRIZZANA SERVO TRAY

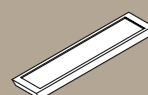

servo portaoggetti
shelf
10x48x3 cm

GRIZZANA SERVO CIRCLE

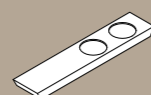

servo portaoggetti
shelf
10x48x3 cm

GRIZZANA SERVO SQUARE

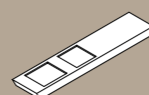

servo portaoggetti
shelf
10x48x3 cm

THE BLACK BROTHERS

design *Ufficio Stile Pibamarmi*

Lavabi in massello
di Nero Marquina

Carved basins
in Nero Marquina

BRONZE GRAY

Rivestimento
in Bronze Gray,
finitura Random

Bronze Gray cladding,
Random surface



GENTILE



AMABILE



ELEGANTE



RUVIDO

THE BLACK BROTHERS

design *Ufficio Stile Pibamarmi*

Amabile
Elegante
Gentile
Ruvido

La capsule collection segue le più aggiornate tendenze contemporanee con quattro lavabi freestanding che presentano forme a calice lisce e sinuose, o rustiche configurazioni di blocchi separati a spacco dal fronte di cava. I “fratelli” sono Ruvido, Elegante, Gentile e Amabile, quattro presenze che richiamano altrettanti caratteri in una stimolante analogia tra qualità sensoriali e personalità dei possibili utenti.

The contemporary capsule collection of four freestanding wash basins shows perfectly polished wine glass profiles or block-like shapes that preserve the signs of the excavating process. These “brothers” are Ruvido, Elegante, Gentile, and Amabile (Rough, Elegant, Gentle and Amable), four presences that translates four characters of the stone in a stimulating analogy between their sensorial qualities and the personalities of the hypothetical users.

RUVIDO

Lavabo in massello
di Nero Marquina

Carved wash basin
in Nero Marquina





ELEGANTE

Lavabo in massello
di Nero Marquina

Carved wash basin
in Nero Marquina



AMABILE

Lavabo in massello
di Nero Marquina

Carved wash basin
in Nero Marquina

INFORMAZIONI TECNICHE
TECHNICAL INFORMATION

GENTILE

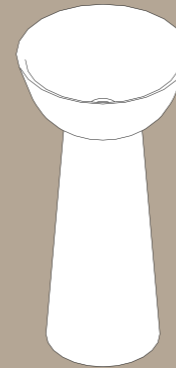

lavabo wash basin
Ø 43x86 cm
140 kg peso *weight*

AMABILE

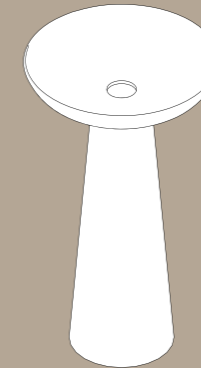

lavabo wash basin
Ø 50x86 cm
150 kg peso *weight*

ELEGANTE

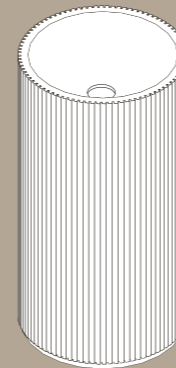

lavabo wash basin
Ø 46x86 cm
180 kg peso *weight*

RUVIDO

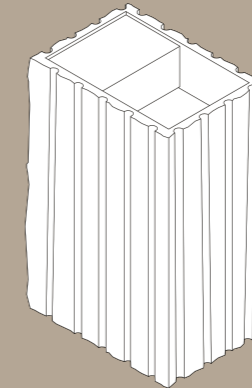

lavabo wash basin
38x54x86 cm
206 kg peso *weight*

STONE LIKES WATER

design *Hikaru Mori*

HIKARU

Rivestimento in
Pietra di Brera,
finitura Patinato

Pietra di Brera cladding,
Patinato surface

FUKUOKA

Lavabo in Nero Assoluto

Wash basin in Nero Assoluto

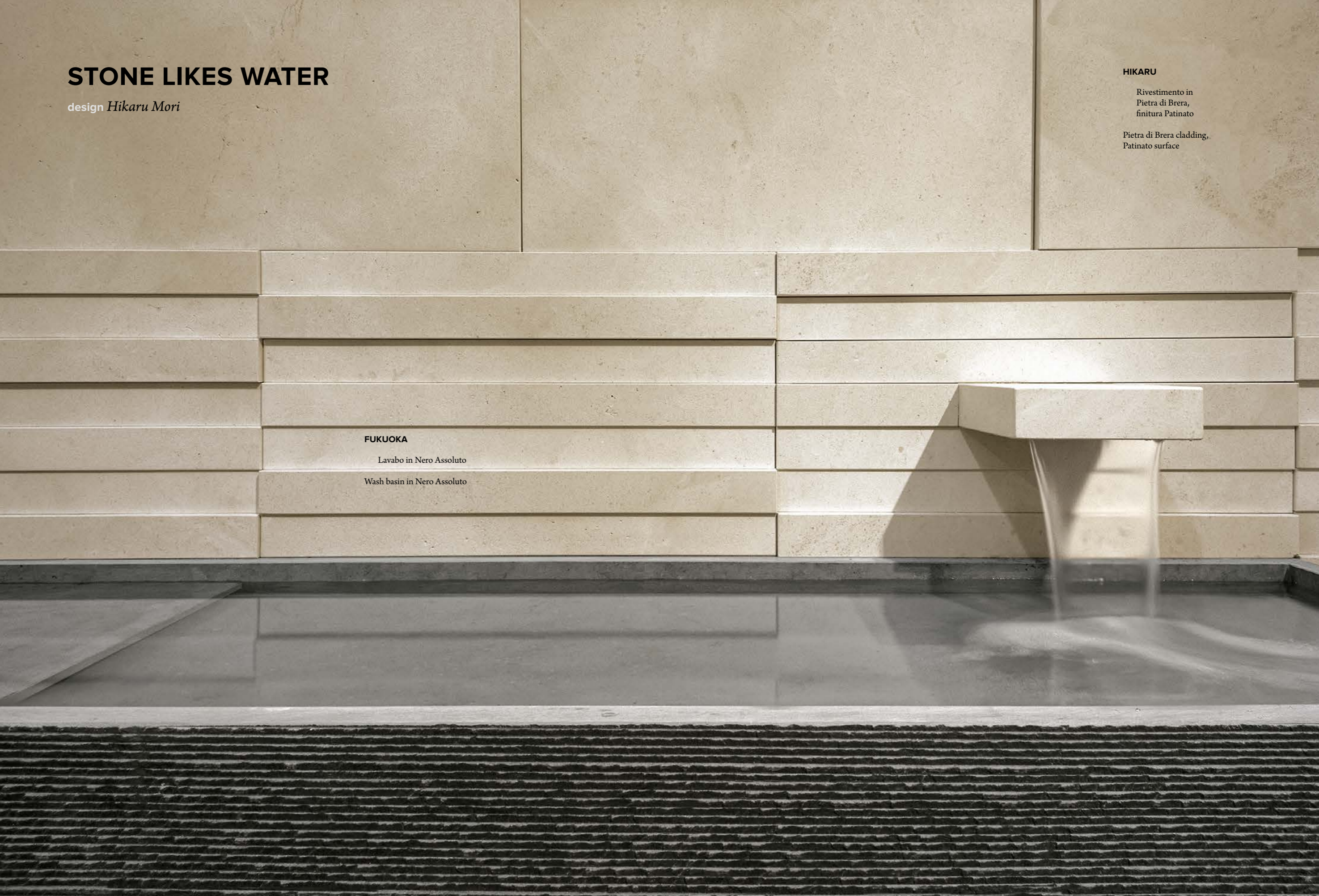

STONE LIKES WATER

design *Hikaru Mori*

Fukuoka
Kobe esterna
Kobe interna
Kyoto
Kyoto con Catino
Nagoya
Osaka
Wabi

Dalla rilettura contemporanea del patrimonio di oggetti ed ambienti della tradizione termale giapponese nasce questa collezione fatta di pietre naturali, di forme essenziali e rigorose, di superfici stimolanti realizzate in funzione del loro rapporto privilegiato con l'acqua.

This collection originates from the contemporary reinterpretation of the heritage of objects and environments in the Japanese thermal bath tradition: it is made of natural stones, of essential and rigorous shapes, of stimulating surfaces conceived to exalt their privileged relationship with water.

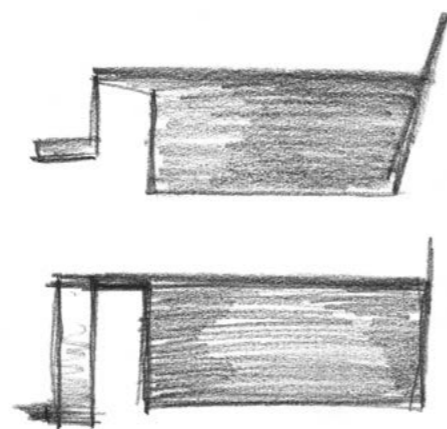

KOBE INTERNA

Vasca in Nero Assoluto

Bathtub in Nero Assoluto



WABI

Vasca in Pietra Senape

Carved bathtub in Pietra Senape

NAGOYA

Seduta in Pietra Senape

Bench in Pietra Senape

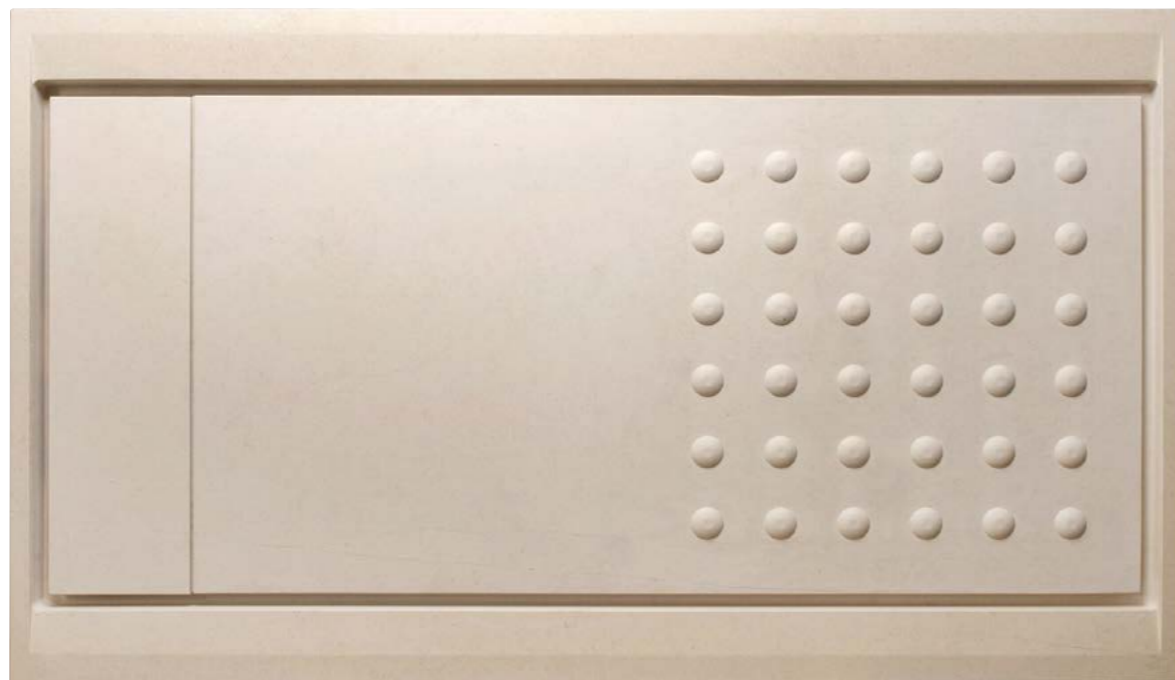

OSAKA

Piatto doccia
in Pietra Senape
con scarico a scomparsa

Shower tray in Pietra Senape
with foldaway drainpipe



KYOTO CON CATINO

Lavabo in Nero Assoluto
Wash basin in Nero Assoluto

NAGOYA

Seduta in Nero Assoluto
Bench in Nero Assoluto



KOBE ESTERNA

Vasca con tracimazione
d'acqua esterna
in Nero Assoluto

Bathtub with overflowing
outside water in Nero Assoluto

INFORMAZIONI TECNICHE TECHNICAL INFORMATION

KYOTO

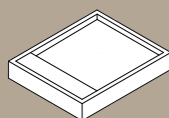

lavabo wash basin
60x50x10 cm
33 kg peso *weight*

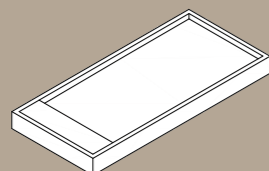

lavabo wash basin
120x50x10 cm
80 kg peso *weight*

FUKUOKA

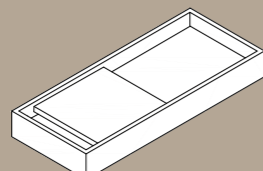

lavabo wash basin
120x50x15 cm
100 kg peso *weight*

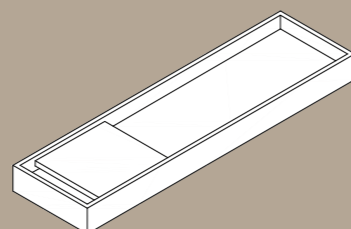

lavabo wash basin
180x50x15 cm
130 kg peso *weight*

KOBE INTERNA

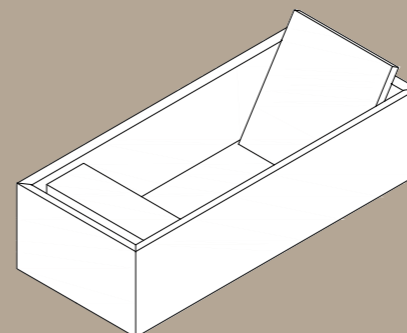

vasca con tracimazione d'acqua interna
bathtub with overflowing inside water
superficie d'appoggio
leaning surface 1,6 mq
400 kg peso *weight*
400 l capacità *capacity*

KOBE ESTERNA

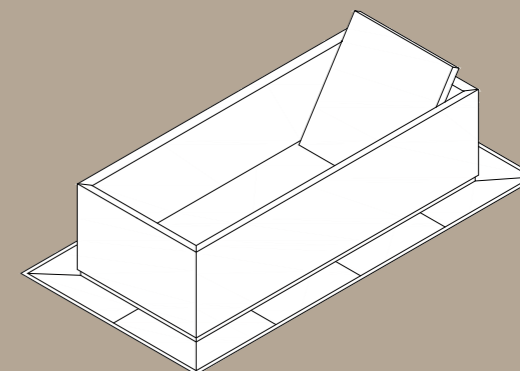

vasca con tracimazione d'acqua esterna
bathtub with overflowing outside water
superficie d'appoggio
leaning surface 1,6 mq
400 kg peso *weight*
400 l capacità *capacity*

KYOTO CON CATINO

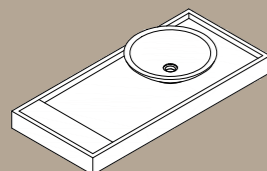

lavabo wash basin
120x50x10 cm
105 kg peso *weight*

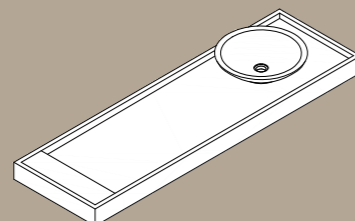

lavabo wash basin
180x50x10 cm
140 kg peso *weight*

NAGOYA

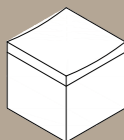

sgabello *bench*
40x40x40 cm
43 kg peso *weight*

OSAKA

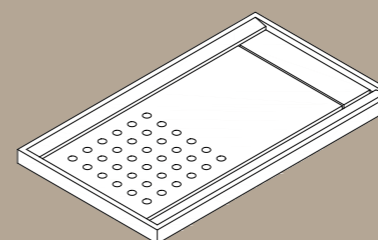

piatto doccia *shower tray*
160x94 cm
250 kg peso *weight*

WABI

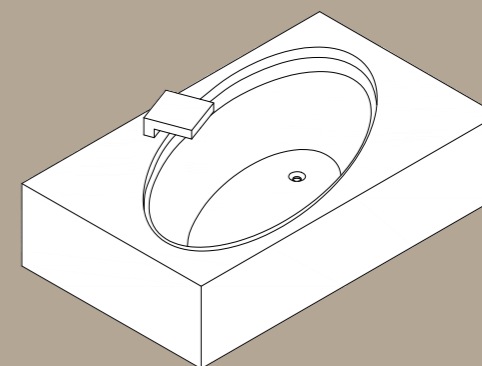

vasca *bathtub*
superficie d'appoggio *leaning surface*
2,4 mq
440 kg peso *weight*
220 l capacità *capacity*

ESCAVO

design *Manuel Aires Mateus*

ARABESCATO STATUARIO

Rivestimento
in Arabescato Statuario,
finitura Patinato

Arabescato Statuario cladding,
Patinato surface

BALDE

Lavabi in massello
di Arabescato Statuario

Carved wash basins
in Arabescato Statuario



ESCAVO

design *Manuel Aires Mateus*

Bacia
Balde
Balde colonna
Banheira circolare
Banheira ovale
Plano

Un design litico semplice e immediato propone figure archetipiche di contenitori per l'acqua come il secchio, la tinozza, il catino. Si tratta di oggetti elementari, per certi versi rudimentali, che tuttavia sul bordo assumono la raffinatezza dei profili sottili e incurvati propri dei vasi e delle stoviglie di porcellana.

This simple and immediate stone design suggests archetypal figures of water holders as buckets, tubs and basins. They are elementary objects, somehow rudimental, which on their edges, however, get a refined look of subtle and rounded profiles typical of vases and chinaware.

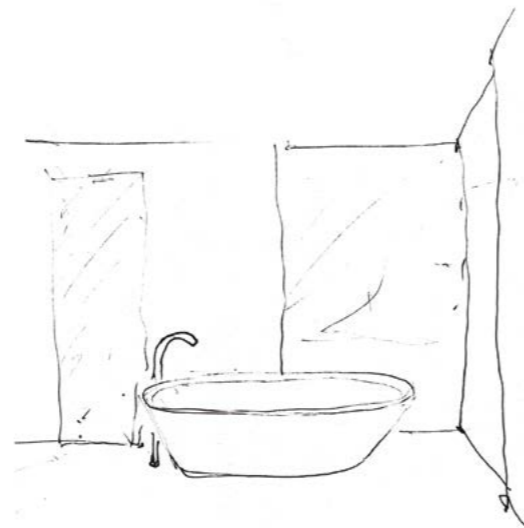

ARABESCATO STATUARIO

Rivestimento
in Arabescato Statuario,
finitura Patinato

Arabescato Statuario cladding,
Patinato surface

BANHEIRA OVALE

Vasca in massello
di Arabescato Statuario

Carved bathtub
in Arabescato Statuario

ARABESCATO STATUARIO

Pavimento
in Arabescato Statuario,
finitura Patinato

Floor in Arabescato Statuario,
Patinato surface



BACIA

Lavabo in massello
di Arabescato Statuario

Carved wash basin
in Arabescato Statuario

BALDE COLONNA

Lavabo in massello
di Arabescato Statuario

Carved wash basin
in Arabescato Statuario

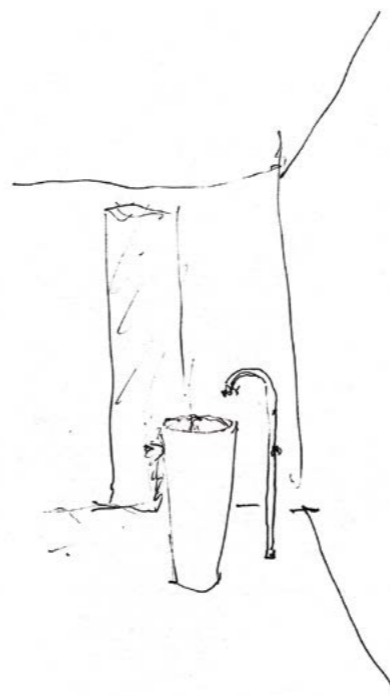

ARABESCATO STATUARIO

Rivestimento
in Arabescato Statuario,
finitura Patinato

Arabescato Statuario cladding,
Patinato surface



BALDE

Lavabi in massello
di Arabescato Statuario

Carved wash basins
in Arabescato Statuario

ARABESCATO STATUARIO

Pavimento in Arabescato
Statuario, finitura Patinato

Floor in Arabescato Statuario,
Patinato surface



PLANO

Piatto doccia in massello
di Arabescato Statuario

Carved shower tray
in Arabescato Statuario

INFORMAZIONI TECNICHE TECHNICAL INFORMATION

BALDE COLONNA



lavabo wash basin
Ø 45x86 cm
150 kg peso *weight*

BALDE



lavabo wash basin
Ø 46x46 cm
75 kg peso *weight*

BACIÀ



lavabo wash basin
Ø 46x12 cm
35 kg peso *weight*

PLANO

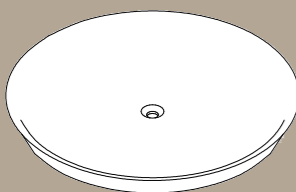

piatto doccia shower tray
Ø 90x8 cm
80 kg peso *weight*

BANHEIRA CIRCOLARE

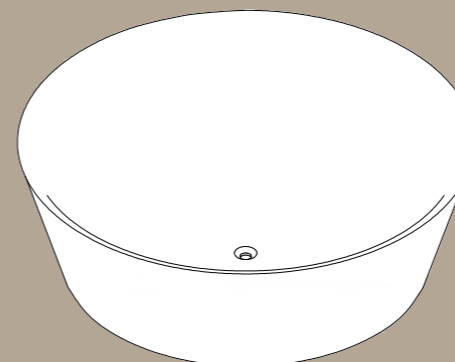

vasca bathtub
Ø 140x46 cm
superficie d'appoggio
leaning surface 0,8 mq
260 kg peso *weight*
220 l capacità *capacity*

BANHEIRA OVALE

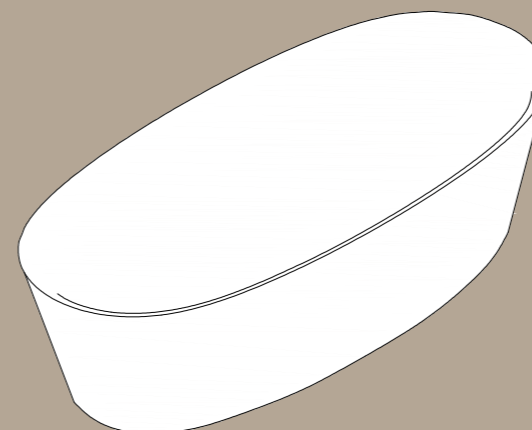

vasca bathtub
170x75x46 cm
superficie d'appoggio
leaning surface 0,7 mq
240 kg peso *weight*
200 l capacità *capacity*

SATURNIA

design *Philippe Nigro*

COLUMN

Lavabo in massello
di Pietra Serena

Carved wash basin
in Pietra Serena



BATH

Vasca in Pietra Serena
realizzata in quattro anelli
scavati sovrapposti
(sistema brevettato)

Bathtub in Pietra Serena,
in four carved rings
(patented system)



SATURNIA SHOWER

Piatto doccia in Pietra Serena
con scarico a scomparsa

Shower tray in Pietra Serena
with foldaway drainpipe



SATURNIA

design *Philippe Nigro*

Basin
Bath
Box
Column
Double Basin
Double Box
Double Sink
Saturnia Shower
Sink

Una riflessione sugli incroci delle genti, dei percorsi e dei linguaggi del mondo globale porta alla composizione di solidi lapidei intersecati, di sequenze di pieni e di vuoti che convergono tra loro, si sovrappongono parzialmente o si fondono del tutto, secondo un processo combinatorio pensato per generare di volta in volta continue inaspettate configurazioni.

A meditation on people, languages, and directions crossing each other in the global world is translated here into a composition of intersected stone solids or sequences of converging full and void spaces, which partially interpose or completely fuse, in a combinatorial process thought to generate several unexpected configurations.

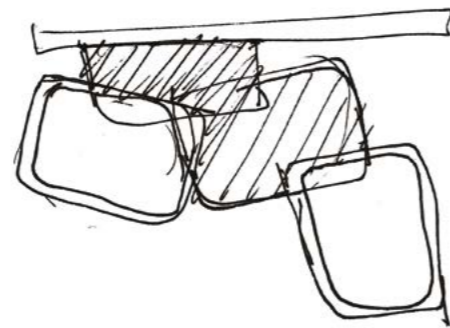

COLUMN

Lavabo in massello
di Pietra Serena

Carved wash basin
in Pietra Serena





BASIN

Lavabo in massello di Grigio di Tunisi con sistema di scarico a scomparsa

Carved wash basin in Grigio di Tunisi with foldaway drainpipe system



BOX

Lavabo in massello di Grigio di Tunisi con sistema di scarico a scomparsa

Carved wash basin in Grigio di Tunisi with foldaway drainpipe system



DOUBLE BASIN

Lavabo in massello di Grigio di Tunisi con sistema di scarico a scomparsa

Carved wash basin in Grigio di Tunisi with foldaway drainpipe system



DOUBLE BOX

Lavabo in massello di Grigio di Tunisi con sistema di scarico a scomparsa

Carved wash basin in Grigio di Tunisi with foldaway drainpipe system

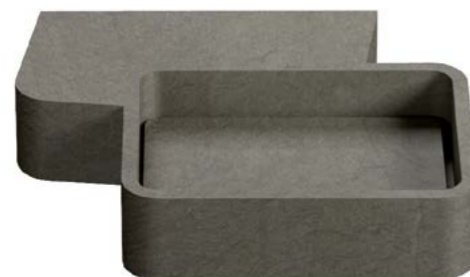

SINK

Lavabo in massello di Grigio di Tunisi con sistema di scarico a scomparsa

Carved wash basin in Grigio di Tunisi with foldaway drainpipe system

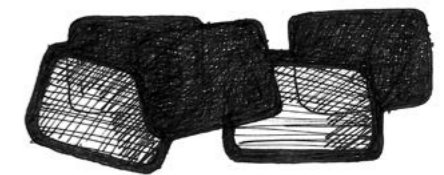
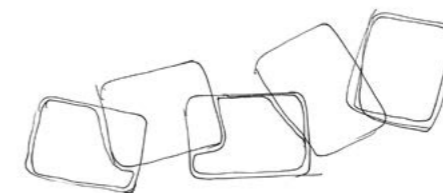

INFORMAZIONI TECNICHE TECHNICAL INFORMATION

SINK

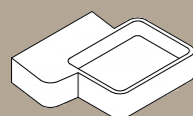

lavabo wash basin
59x50x12 cm
65 kg peso weight

DOUBLE SINK

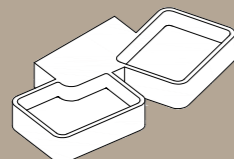

lavabo wash basin
103x50x12 cm
90 kg peso weight

BASIN

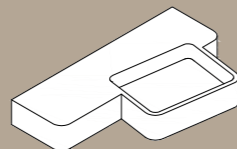

lavabo wash basin
90x54x12 cm
75 kg peso weight

DOUBLE BASIN

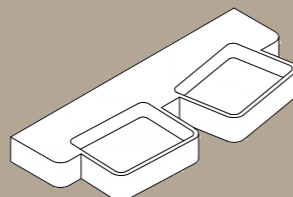

lavabo wash basin
125x54x12 cm
98 kg peso weight

COLUMN

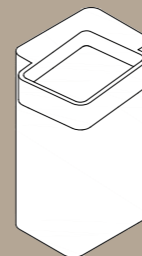

lavabo wash basin
54x50x84 cm
170 kg peso weight

SATURNIA SHOWER

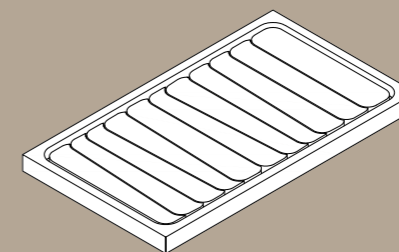

piatto doccia shower tray
140x80x8 cm
195 kg peso weight

BOX

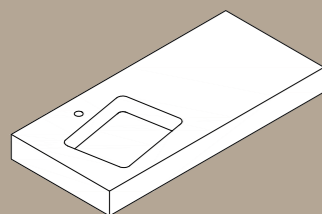

lavabo wash basin
120x55x12 cm
75 kg peso weight

DOUBLE BOX

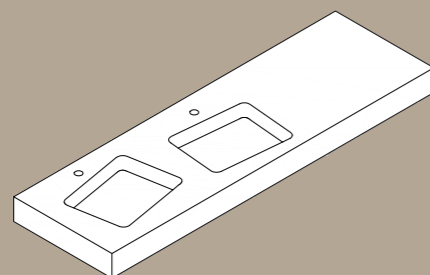

lavabo wash basin
180x55x12 cm
110 kg peso weight

BATH

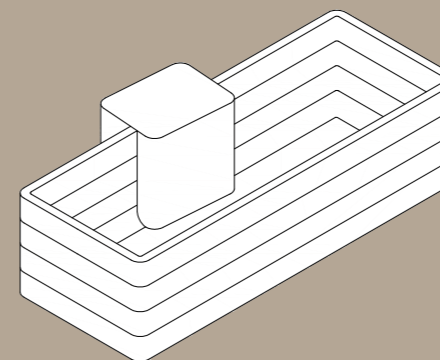

vasca bathtub
120-180x70x54 cm
superficie d'appoggio
leaning surface 0,65 mq
430 kg peso weight
380 l capacità capacity

PLAY

design *VISTO aw*

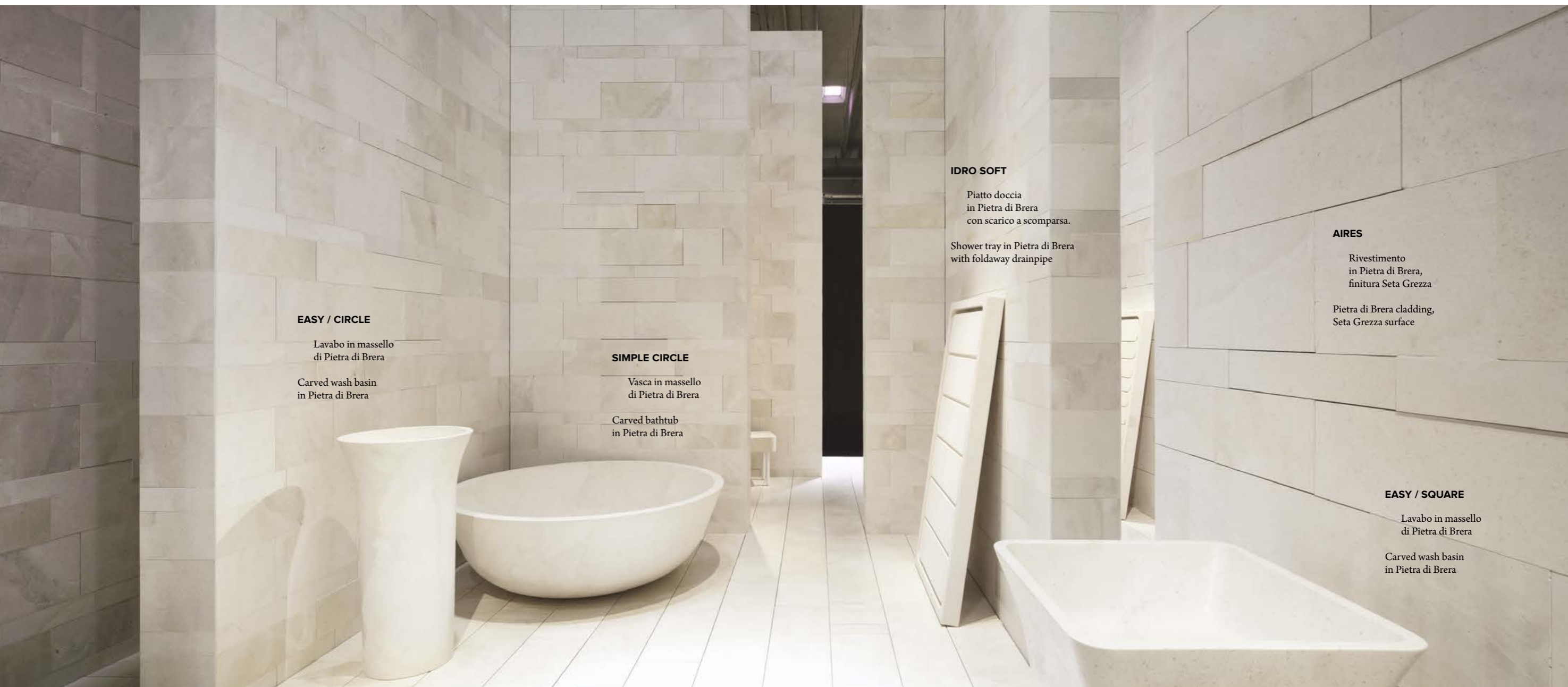

EASY / CIRCLE

Lavabo in massello
di Pietra di Brera

Carved wash basin
in Pietra di Brera

SIMPLE CIRCLE

Vasca in massello
di Pietra di Brera

Carved bathtub
in Pietra di Brera

IDRO SOFT

Piatto doccia
in Pietra di Brera
con scarico a scomparsa.

Shower tray in Pietra di Brera
with foldaway drainpipe

AIRES

Rivestimento
in Pietra di Brera,
finitura Seta Grezza

Pietra di Brera cladding,
Seta Grezza surface

EASY / SQUARE

Lavabo in massello
di Pietra di Brera

Carved wash basin
in Pietra di Brera

PLAY

design *VISTO aw*

Easy / Circle
Easy / Square
Idro Soft
Quick / Circle
Quick / Square
Simple Circle
Simple Ellipse

Oggetti leggeri e compatti che parlano in maniera piana e accessibile il linguaggio di una modernità senza tempo, fatta di linee morbide ed essenziali; di geometrie circolari, ellittiche o quadrate con spigoli smussati; di dimensioni contenute che ben si adattano ai vani spesso minimi dei bagni contemporanei.

These light and compact objects speak in a full and accessible manner the language of a timeless contemporaneity made of soft and essential lines; of geometries that are circular, elliptical or squared with rounded corners; of limited dimensions adapting to the often restricted measures of contemporary bathrooms.

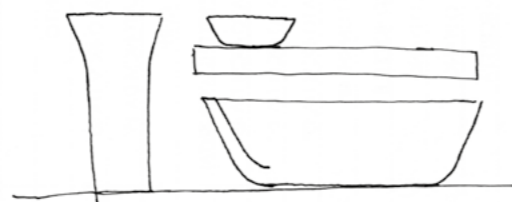

AIRES

Rivestimento
in Pietra di Brera,
finitura Seta Grezza

Pietra di Brera cladding,
Seta Grezza surface

SIMPLE ELLIPSE

Vasca in massello
di Pietra di Brera

Carved bathtub
in Pietra di Brera



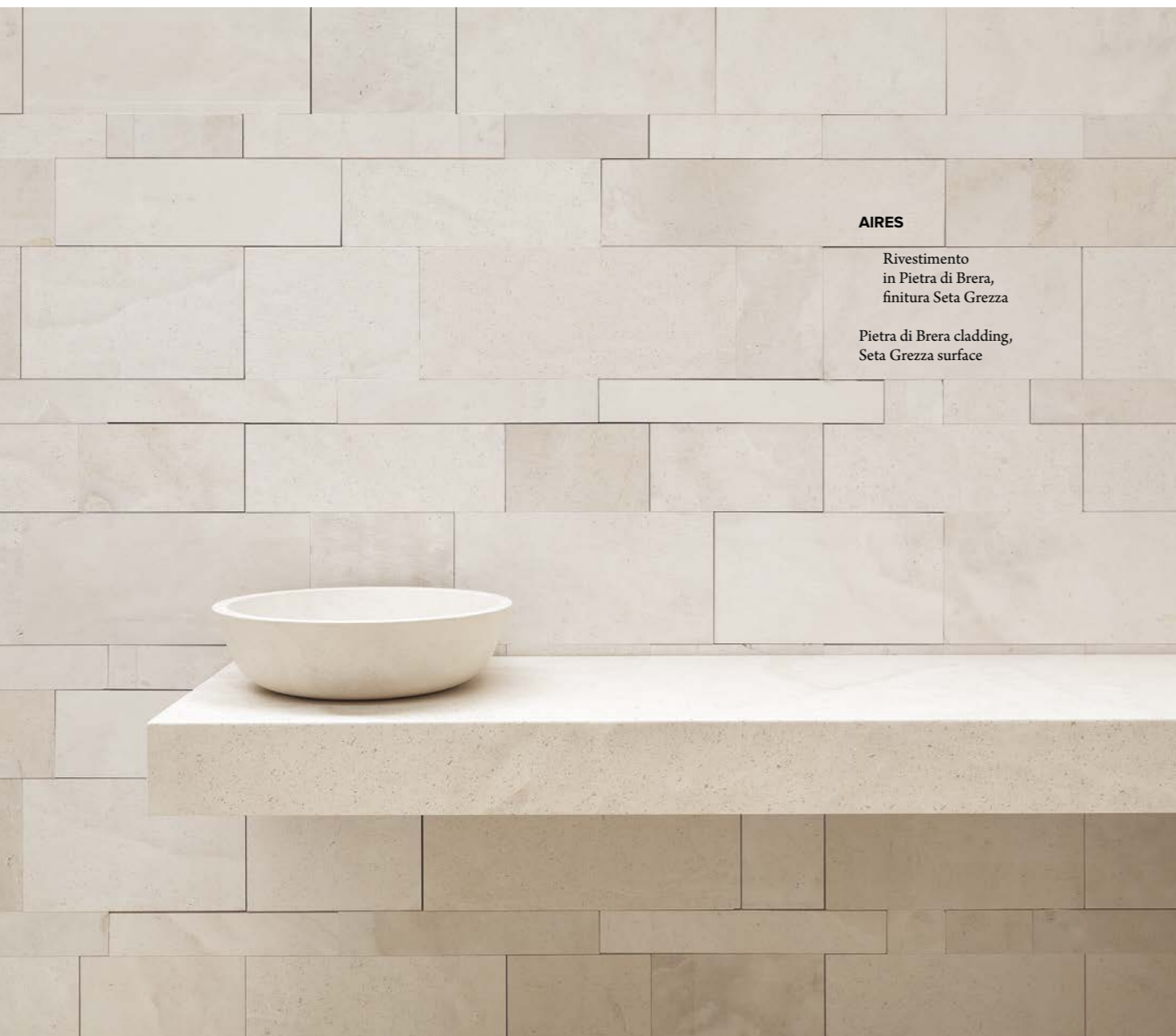

AIRES

Rivestimento
in Pietra di Brera,
finitura Seta Grezza

Pietra di Brera cladding,
Seta Grezza surface

QUICK / CIRCLE

Lavabo da appoggio
in massello di Pietra di Brera

Carved wash basin
in Pietra di Brera; to be leaned

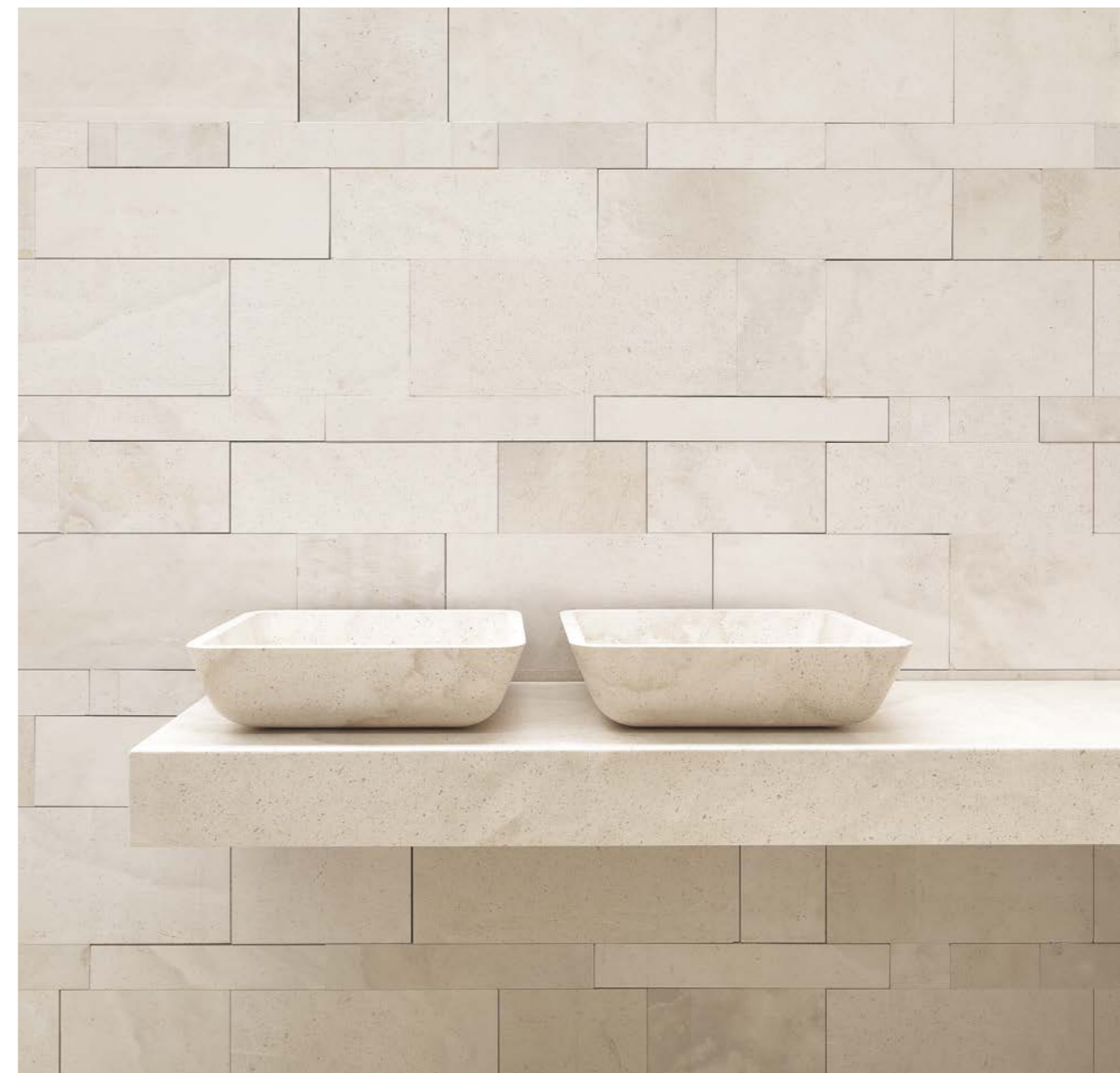

QUICK / SQUARE

Lavabi da appoggio
in massello di Pietra di Brera

Carved wash basins
in Pietra di Brera; to be leaned

INFORMAZIONI TECNICHE TECHNICAL INFORMATION

QUICK / CIRCLE

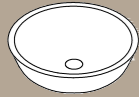

lavabo *wash basin*
Ø 45x12 cm
25 kg peso *weight*

QUICK / SQUARE

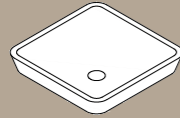

lavabo *wash basin*
45x45x12 cm
25 kg peso *weight*

EASY / CIRCLE

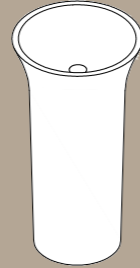

lavabo *wash basin*
Ø 45x85 cm
150 kg peso *weight*

EASY / SQUARE

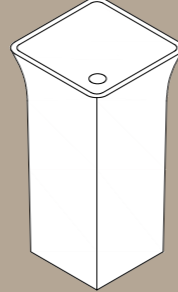

lavabo *wash basin*
45x45x85 cm
150 kg peso *weight*

SIMPLE CIRCLE

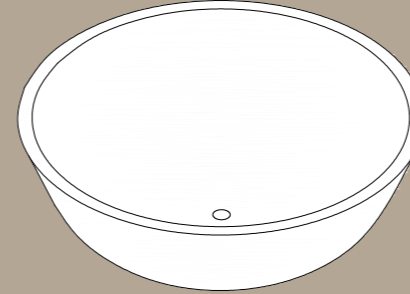

vasca *bathtub*
Ø 140x46 cm
superficie d'appoggio
leaning surface 0,4 mq
280 kg peso *weight*
250 l capacità *capacity*

IDRO SOFT

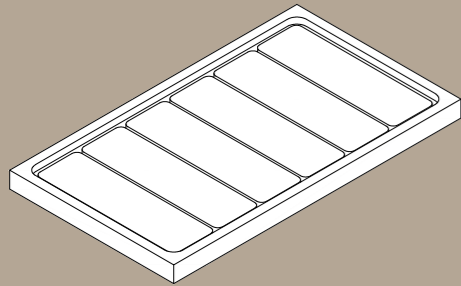

piatto doccia *shower tray*
140x80 cm
195 kg peso *weight*

SIMPLE ELLIPSE

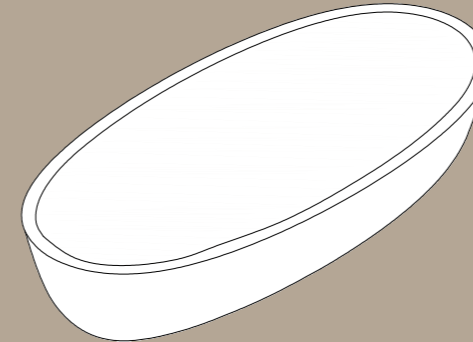

vasca *bathtub*
200x95x46 cm
superficie d'appoggio
leaning surface 0,8 mq
350 kg peso *weight*
280 l capacità *capacity*

BASIC COLLECTION

design *Ufficio Stile Pibamarmi*



IDRO RULER

Piatto doccia in Grigio Ash
con scarico a scomparsa

Shower tray in Grigio Ash
with foldaway drainpipe

TABLA CON CATINO

Sistema di piani lavabo
realizzati con lunghezze
a richiesta in lastre
assemblate. Materiali
Pietra Zen e Grigio Ash

Washing plane system realized
with assembled slabs, length
on demand. Materials Pietra Zen
and Grigio Ash

TINOZZA

Vasca in Pietra Zen realizzata
in un massello unico o in
tre anelli (sistema brevettato)

Bathtub in Pietra Zen, in solid stone
or in three rings (patented system)

BASIC COLLECTION

design *Ufficio Stile Pibamarmi*

Presenze scultoree ottenute per scavo di interi monoliti con tagli fluidi e continui; sanitari dai profili netti; corpi plastici puri e omogenei caratterizzati da contrapposizioni volumetriche di vuoti e di pieni, da contrasti tra luci ed ombre in suggestivi effetti chiaroscurali.

This simple and immediate stone design suggests archetypal figures of water holders as buckets, tubs and basins. They are elementary objects, somehow rudimental, which on their edges, however, get a refined look of subtle and rounded profiles typical of vases and chinaware.

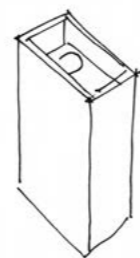
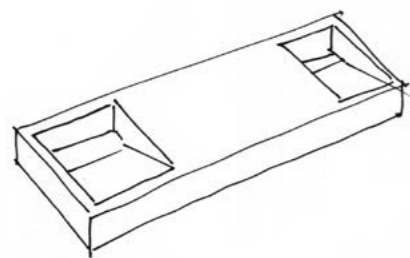

Barrique
Catino
Citrohan
Citrohan doppia
Egg
Fedaja
Fimon
Idro Circle
Idro Plank
Idro Ruler
Idro Strip
Jeanneret
Lugano
M45
M45 + vanity top
Minimal
Ozenfant
Slope
Superpila
Tabla con Catino
Thin
Tinozza
Wok



TABLA CON CATINO

Sistema di lavabi e piani realizzati con lunghezza a richiesta in lastre assemblate. Materiali Nero Assoluto e Pietra Senape

Wash basin and plane system realized with assembled slabs, length on demand. Materials Nero Assoluto and Pietra Senape



SUPERPILA

Lavabo in Pietra di Brera

Wash basin in Pietra di Brera



SLOPE

Lavabo in Pietra Zen
con sistema di scarico
a scomparsa

Wash basin in Pietra Zen
with foldaway drainpipe system



MINIMAL

Lavabo in Grigio Ash

Wash basin in Grigio Ash



OZENFANT

Lavabo in Pietra di Brera
realizzato in tre elementi
sovrapponibili

Carved wash basin in Pietra
di Brera realized by three
superimposable elements



IDRO STRIP



FIMON



LUGANO



IDRO PLANK



FEDAJA



IDRO CIRCLE

Piatti doccia in pietra scavata
con scarico a scomparsa

Carved stone shower trays
with foldaway drainpipe

Piatti doccia in pietra scavata
con scarico a scomparsa

Carved stone shower trays
with foldaway drainpipe

INFORMAZIONI TECNICHE
TECHNICAL INFORMATION

WOK

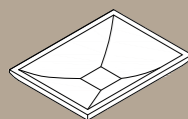

lavabo wash basin
60x44x12 cm
33 kg peso *weight*

M45

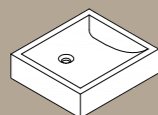

lavabo wash basin
45x40x12 cm
32 kg peso *weight*

M45 + VANITY TOP

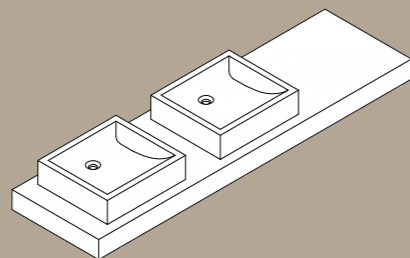

lavabo wash basin
120x50x10 cm
2xM45 + piano d'appoggio
leaning plane 115 kg peso *weight*

BARRIQUE

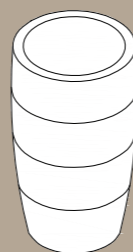

lavabo wash basin
Ø 50x90 cm
160 kg peso *weight*

SUPERPILA

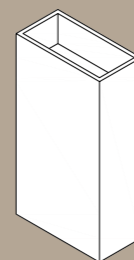

lavabo wash basin
48x24x90 cm
90 kg peso *weight*

MINIMAL 90

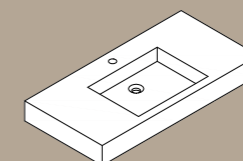

lavabo wash basin
90x45x10 cm
46 kg peso *weight*

CATINO



lavabo wash basin
Ø 50x12 cm
29 kg peso *weight*

TABLA CON CATINO

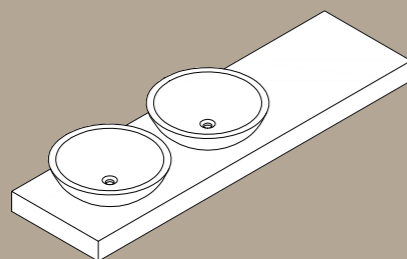

piano *plane*
Ø 50x12 cm
38 kg peso per ml
weight per mt
length

OZENFANT



lavabo wash basin
Ø 45,5x50 cm
85 kg peso *weight*

EGG



lavabo wash basin
Ø 55x34,5 cm
85 kg peso *weight*

SLOPE

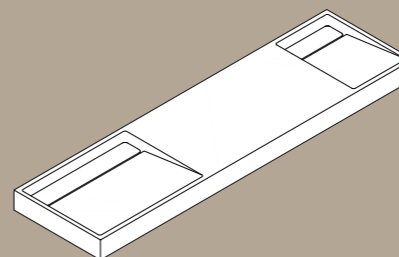

lavabo wash basin
180x50x12 cm
115 kg peso *weight*

JEANNERET

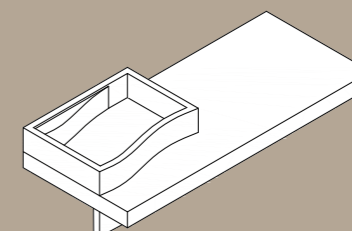

lavabo wash basin
140x50x32 cm
110 kg peso *weight*

FEDAJA

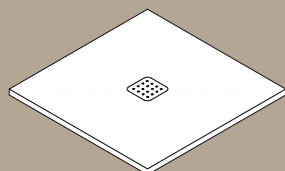

piatto doccia *shower tray*
80x80/90x90x3 + 3 cm
70 kg peso *weight*

FIMON

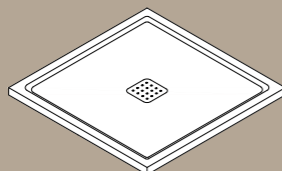

piatto doccia *shower tray*
80x80/90x90x4 + 3 cm
80 kg peso *weight*

LUGANO

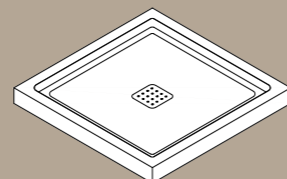

piatto doccia *shower tray*
80x80/90x90x8 cm
90 kg peso *weight*

IDRO PLANK

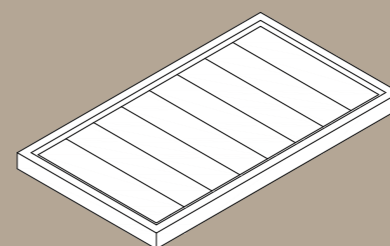

piatto doccia *shower tray*
140x80x8 cm
195 kg peso *weight*

TINOZZA

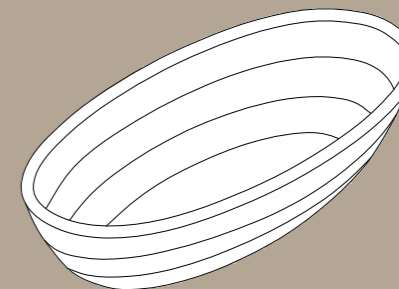

vasca *bathtub*
200x100x46 cm
superficie d'appoggio
leaning surface 0,8 mq
350 kg peso *weight*
280 l capacità *capacity*

IDRO CIRCLE

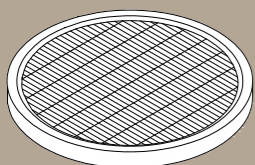

piatto doccia *shower tray*
Ø 90x8 cm
165 kg peso *weight*

IDRO RULER

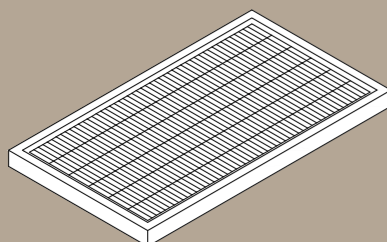

piatto doccia *shower tray*
140x80x8 cm
195 kg peso *weight*

IDRO STRIP

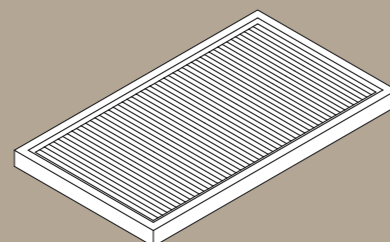

piatto doccia *shower tray*
140x80x8 cm
195 kg peso *weight*

CITROHAN

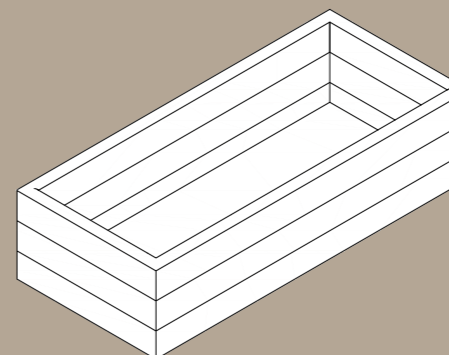

vasca *bathtub*
180x80x53 cm
superficie d'appoggio
leaning surface 0,77 mq
480 kg peso *weight*
390 l capacità *capacity*

CITROHAN DOPPIA

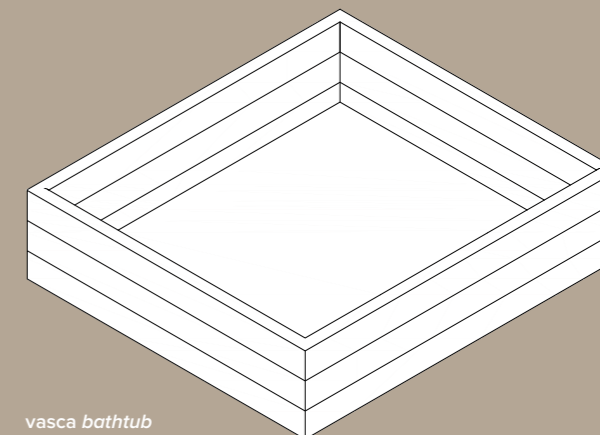

vasca *bathtub*
180x140x55 cm
superficie d'appoggio
leaning surface 1,5 mq
740 kg peso *weight*
700 l capacità *capacity*

MATERIALI MATERIALS

PIETRE E MARMI NATURALI NATURAL MARBLES AND STONES

| | |
|-----------------------------|------------------------------|
| Arabescato Statuario | Iceland Gray |
| Bianco Carrara | Nero Assoluto Granito |
| Bianco Lybra | Nero Marquinia |
| Bianco Perlino | Nero Pepe |
| Botticino | New Granada Beige |
| Bronze Gray | Onice Bianco |
| Calacatta Oro | Onice Miele |
| Crema Caribe | Pietra Brown |
| Crema Luna | Pietra di Brera |
| Crema Vicenza | Pietra Gray |
| Cristallino Hebron | Pietra Lavica |
| Ebano | Pietra Senape |
| Giallo Mediterraneo | Pietra Zen |
| Grigio Ash | Rosso Etrusco |
| Grigio Bardiglio | Rosso Levante |
| Grigio dei Navigli | Travertino Bianco |
| Grigio di Tunisi | Travertino Chiaro |
| Grigio Portaluppi | Travertino Milano |
| Grigio Siviglia | Travertino Noce |
| Iceland Dark | Verde Barcellona |

Pibamarmi commercializza e lavora pietre e marmi di elevata qualità, selezionando i materiali in Italia e nei paesi dell'area mediterranea. Grigio Ash, Pietra Senape, Nero Assoluto, sono alcuni dei nomi che il brand di Chiampo assegna ai suoi litotipi, impiegati per dar corpo a progetti di architettura, allestimenti d'interni, oggetti di design. Da tempo e con continuità, tali denominazioni affermano un'identità chiara e riconoscibile in un mercato sempre più caratterizzato da un'elevata concorrenza e da una rapida mutazione.

Pibamarmi sells and works with high-quality stones and marbles, choosing the best materials in Italy and in the Mediterranean countries. Grigio Ash, Pietra Senape, and Nero Assoluto are some of the names given by the brand to its lithotypes, used to create architectural projects, interior designs and furnishing elements. For long time these trademarks has given Pibamarmi a recognizable and distinctive identity in a market always more characterized by quick evolution and strong competition.



Le immagini dei marmi e delle pietre sono puramente indicative. Sensibili variazioni di tono e venatura sono tipiche dei materiali lapidei naturali

The images of marbles and stones are to be considered strictly nominal. Natural materials can undergo changes in colour and vein



BIANCO LYBRA



CREMA LUNA



BIANCO PERLINO



CREMA VICENZA



PIETRA ZEN



PIETRA DI BRERA



GIALLO MEDITERRANEO

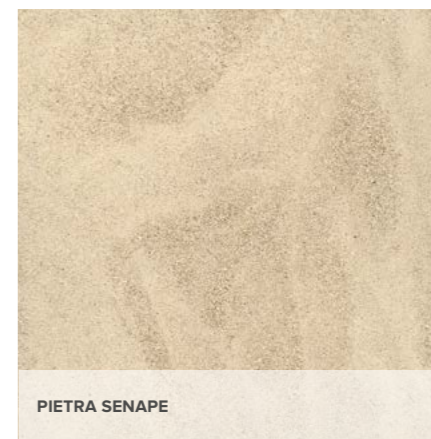

PIETRA SENAPE

| Materiale <i>Material</i> | Tipologia <i>Type</i> | Percentuale assorbenza dell'acqua <i>Water absorption</i> | Applicazioni consigliate <i>Prevalent use</i> | Produzione della cava <i>Quarry production</i> |
|------------------------------|--|--|---|---|
| BIANCO LYBRA | Limestone | 3,90 % | Interni <i>Inside</i> | Limitata <i>Limited</i> |
| CREMA LUNA | Limestone | 2,90 % | Interni/Esterni <i>Inside/Outside</i> | Buona <i>Good</i> |
| BIANCO PERLINO | Marmo calcareo <i>Calcareous marble</i> | 1,00 % | Interni/Esterni <i>Inside/Outside</i> | Buona <i>Good</i> |
| CREMA VICENZA | Marmo calcareo <i>Calcareous marble</i> | 0,58 % | Interni <i>Inside</i> | Buona <i>Good</i> |

| Materiale <i>Material</i> | Tipologia <i>Type</i> | Percentuale assorbenza dell'acqua <i>Water absorption</i> | Applicazioni consigliate <i>Prevalent use</i> | Produzione della cava <i>Quarry production</i> |
|------------------------------|--|--|---|---|
| PIETRA ZEN | Limestone | 2,60 % | Interni <i>Inside</i> | Buona <i>Good</i> |
| PIETRA DI BRERA | Marmo calcareo <i>Calcareous marble</i> | 1,04 % | Interni <i>Inside</i> | Buona <i>Good</i> |
| GIALLO MEDITERRANEO | Marmo calcareo <i>Calcareous marble</i> | 0,58 % | Interni <i>Inside</i> | Buona <i>Good</i> |
| PIETRA SENAPE | Limestone | 3,10 % | Interni/Esterni <i>Inside/Outside</i> | Buona <i>Good</i> |



BIANCO CARRARA



ARABESCATO STATUARIO

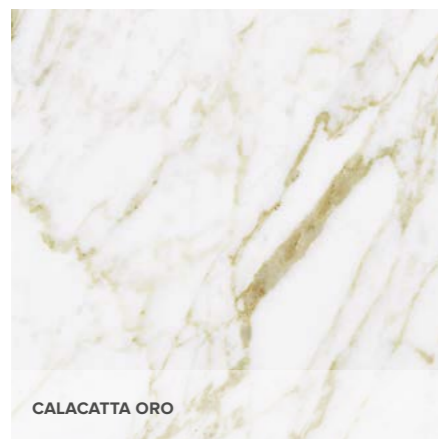

CALACATTA ORO



CRISTALLINO HEBRON

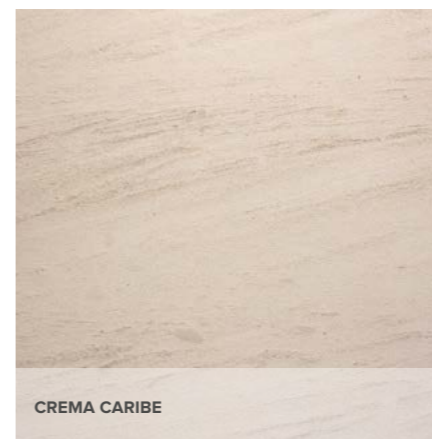

CREMA CARIBE



TRAVERTINO CHIARO



BOTTICINO



NEW GRANADA BEIGE

| Materiale <i>Material</i> | Tipologia <i>Type</i> | Percentuale assorbenza dell'acqua <i>Water absorption</i> | Applicazioni consigliate <i>Prevalent use</i> | Produzione della cava <i>Quarry production</i> |
|------------------------------|--|--|---|---|
| BIANCO CARRARA | Marmo cristallino <i>Crystalline marble</i> | 0,96 % | Interni/Esterni <i>Inside/Outside</i> | Buona <i>Good</i> |
| ARABESCATO STATUARIO | Statuario | 0,30 % | Interni <i>Inside</i> | Limitata <i>Limited</i> |
| CALACATTA ORO | Marmo cristallino <i>Crystalline marble</i> | 0,32 % | Interni <i>Inside</i> | Limitata <i>Limited</i> |
| CRISTALLINO HEBRON | Marmo cristallino <i>Crystalline marble</i> | 1,10 % | Interni/Esterni <i>Inside/Outside</i> | Buona <i>Good</i> |

| Materiale <i>Material</i> | Tipologia <i>Type</i> | Percentuale assorbenza dell'acqua <i>Water absorption</i> | Applicazioni consigliate <i>Prevalent use</i> | Produzione della cava <i>Quarry production</i> |
|------------------------------|--|--|---|---|
| CREMA CARIBE | Limestone | 2,60 % | Interni <i>Inside</i> | Buona <i>Good</i> |
| TRAVERTINO CHIARO | Travertino <i>Travertine</i> | 5-8 % | Interni/Esterni <i>Inside/Outside</i> | Buona <i>Good</i> |
| BOTTICINO | Marmo calcareo <i>Calcareous marble</i> | 0,55 % | Interni/Esterni <i>Inside/Outside</i> | Buona <i>Good</i> |
| NEW GRANADA BEIGE | Marmo calcareo <i>Calcareous marble</i> | 1,64 % | Interni/Esterni <i>Inside/Outside</i> | Buona <i>Good</i> |



ICELAND GRAY



GRIGIO DEI NAVIGLI



ICELAND DARK



GRIGIO BARDIGLIO



GRIGIO SIVIGLIA



GRIGIO ASH



GRIGIO DI TUNISI



TRAVERTINO MILANO

| Materiale <i>Material</i> | Tipologia <i>Type</i> | Percentuale assorbenza dell'acqua <i>Water absorption</i> | Applicazioni consigliate <i>Prevalent use</i> | Produzione della cava <i>Quarry production</i> |
|------------------------------|--|--|---|---|
| ICELAND GRAY | Marmo calcareo <i>Calcareous marble</i> | 1,05 % | Interni <i>Inside</i> | Limitata <i>Limited</i> |
| GRIGIO DEI NAVIGLI | Marmo calcareo <i>Calcareous marble</i> | 0,96 % | Interni <i>Inside</i> | Buona <i>Good</i> |
| ICELAND DARK | Marmo calcareo <i>Calcareous marble</i> | 1,05 % | Interni <i>Inside</i> | Limitata <i>Limited</i> |
| GRIGIO BARDIGLIO | Marmo calcareo <i>Calcareous marble</i> | 1,60 % | Interni/Esterni <i>Inside/Outside</i> | Limitata <i>Limited</i> |

| Materiale <i>Material</i> | Tipologia <i>Type</i> | Percentuale assorbenza dell'acqua <i>Water absorption</i> | Applicazioni consigliate <i>Prevalent use</i> | Produzione della cava <i>Quarry production</i> |
|------------------------------|--|--|---|---|
| GRIGIO SIVIGLIA | Marmo calcareo <i>Calcareous marble</i> | 0,41 % | Interni/Esterni <i>Inside/Outside</i> | Buona <i>Good</i> |
| GRIGIO ASH | Limestone | 3,20 % | Interni <i>Inside</i> | Buona <i>Good</i> |
| GRIGIO DI TUNISI | Limestone | 1,20 % | Interni/Esterni <i>Inside/Outside</i> | Buona <i>Good</i> |
| TRAVERTINO MILANO | Travertino <i>Travertine</i> | 5-8 % | Interni <i>Inside</i> | Limitata <i>Limited</i> |



GRIGIO PORTALUPPI



PIETRA LAVICA

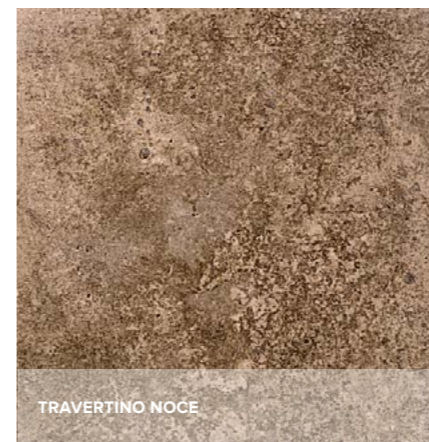

TRAVERTINO NOCE

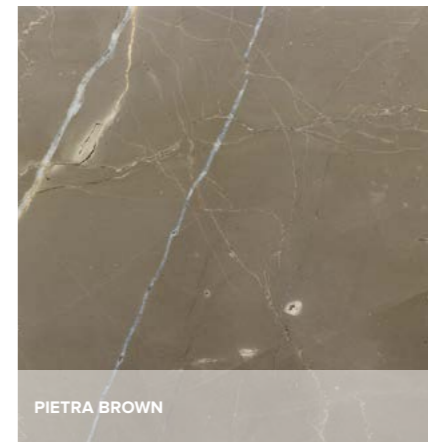

PIETRA BROWN

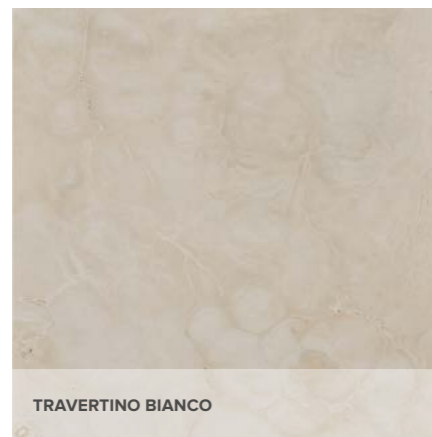

TRAVERTINO BIANCO



BRONZE GRAY



ROSSO ETRUSCO

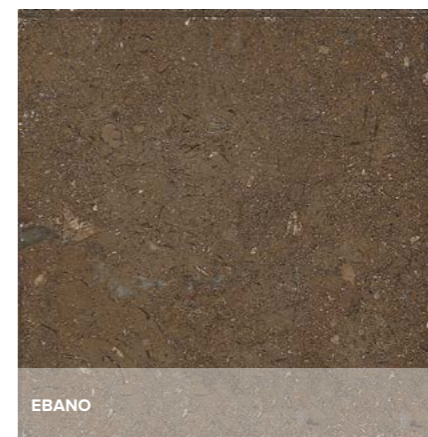

EBANO

| Material <i>Material</i> | Tipologia <i>Type</i> | Percentuale assorbenza dell'acqua <i>Water absorption</i> | Applicazioni consigliate <i>Prevalent use</i> | Produzione della cava <i>Quarry production</i> |
|-----------------------------|--|--|---|---|
| GRIGIO PORTALUPPI | Marmo calcareo <i>Calcareous marble</i> | 0,45 % | Interni <i>Inside</i> | Buona <i>Good</i> |
| PIETRA LAVICA | Lava | 5-8 % | Interni/Esterni <i>Inside/Outside</i> | Limitata <i>Limited</i> |
| TRAVERTINO BIANCO | Travertino <i>Travertine</i> | 5-8 % | Interni <i>Inside</i> | Limitata <i>Limited</i> |
| BRONZE GRAY | Marmo calcareo <i>Calcareous marble</i> | 0,55 % | Interni <i>Inside</i> | Buona <i>Good</i> |

| Material <i>Material</i> | Tipologia <i>Type</i> | Percentuale assorbenza dell'acqua <i>Water absorption</i> | Applicazioni consigliate <i>Prevalent use</i> | Produzione della cava <i>Quarry production</i> |
|-----------------------------|--|--|---|---|
| TRAVERTINO NOCE | Travertino <i>Travertine</i> | 5-8 % | Interni/Esterni <i>Inside/Outside</i> | Limitata <i>Limited</i> |
| PIETRA BROWN | Marmo calcareo <i>Calcareous marble</i> | 0,27 % | Interni <i>Inside</i> | Limitata <i>Limited</i> |
| ROSSO ETRUSCO | Pietra arenaria <i>Sandstone</i> | 1,76 % | Interni/Esterni <i>Inside/Outside</i> | Limitata <i>Limited</i> |
| EBANO | Limestone | 1,80 % | Interni <i>Inside</i> | Buona <i>Good</i> |



NERO PEPE



NERO ASSOLUTO GRANITO



PIETRA GREY

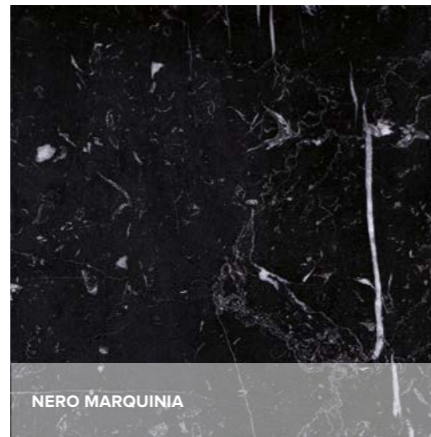

NERO MARQUINA



ONICE BIANCO



ONICE MIELE

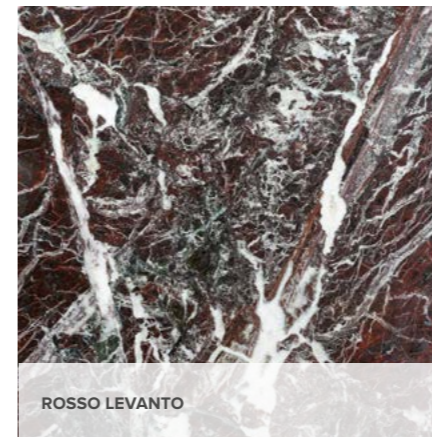

ROSSO LEVANTO

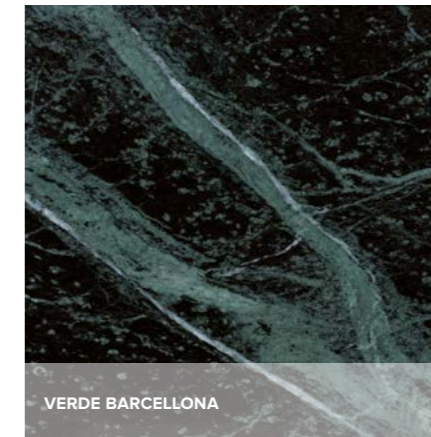

VERDE BARCELLONA

| Materiale <i>Material</i> | Tipologia <i>Type</i> | Percentuale assorbenza dell'acqua <i>Water absorption</i> | Applicazioni consigliate <i>Prevalent use</i> | Produzione della cava <i>Quarry production</i> |
|------------------------------|--|--|---|---|
| NERO PEPE | Marmo calcareo <i>Calcareous marble</i> | 0,54 % | Interni/Esterni <i>Inside/Outside</i> | Buona <i>Good</i> |
| NERO ASSOLUTO GRANITO | Granito <i>Granit</i> | 0,70 % | Interni/Esterni <i>Inside/Outside</i> | Buona <i>Good</i> |
| PIETRA GREY | Marmo calcareo <i>Calcareous marble</i> | 0,78 % | Interni/Esterni <i>Inside/Outside</i> | Buona <i>Good</i> |
| NERO MARQUINA | Marmo calcareo <i>Calcareous marble</i> | 0,90 % | Interni <i>Inside</i> | Limitata <i>Limited</i> |

| Materiale <i>Material</i> | Tipologia <i>Type</i> | Percentuale assorbenza dell'acqua <i>Water absorption</i> | Applicazioni consigliate <i>Prevalent use</i> | Produzione della cava <i>Quarry production</i> |
|------------------------------|--------------------------------|--|---|---|
| ONICE BIANCO | Onice <i>Onyx</i> | 0,95 % | Interni <i>Inside</i> | Limitata <i>Limited</i> |
| ONICE MIELE | Onice <i>Onyx</i> | 1,05 % | Interni <i>Inside</i> | Limitata <i>Limited</i> |
| ROSSO LEVANTO | Oficalce <i>Ophicalcite</i> | 0,75 % | Interni <i>Inside</i> | Buona <i>Good</i> |
| VERDE BARCELLONA | Oficalce <i>Ophicalcite</i> | 0,60 % | Interni <i>Inside</i> | Buona <i>Good</i> |

SUPERFICI
SURFACES



SLASH BRONZE GRAY

Le finiture sono disponibili
in tutte le varietà dei materiali
a catalogo

Surfaces are available
in all our marbles



LUCIDO BRONZE GRAY

formato 30x30 cm



zoom



RULLATO FINE BRONZE GRAY

formato 30x30 cm



zoom

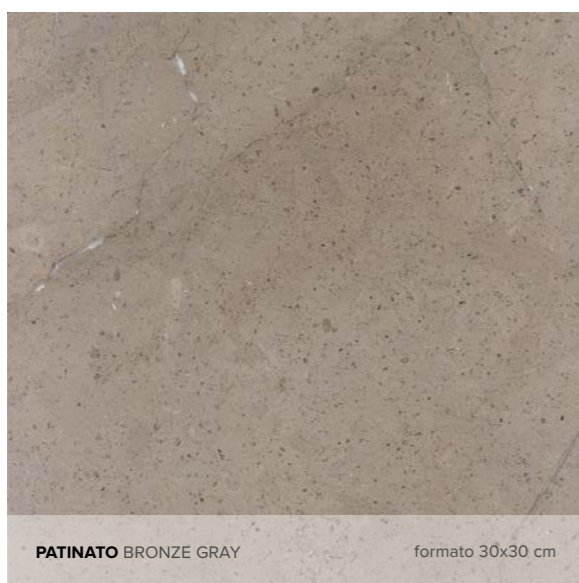

PATINATO BRONZE GRAY

formato 30x30 cm

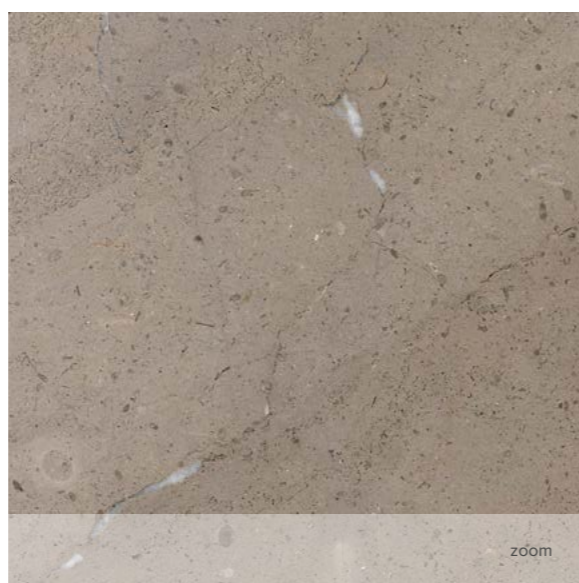

zoom



BOCCIARDATO BRONZE GRAY

formato 30x30 cm



zoom

Le finiture sono disponibili
in tutte le varietà dei materiali
a catalogo

Surfaces are available
in all our marbles



La finitura Random
è disponibile solo per
il materiale Bronze Gray

Random surface is available
only for Bronze Gray stone



formato 30x30 cm



formato 30x30 cm





RIGATINO BRONZE GRAY

formato 30x30 cm



zoom



CANALETTO BRONZE GRAY

formato 30x30 cm



zoom



RIGATO BRONZE GRAY

formato 30x30 cm

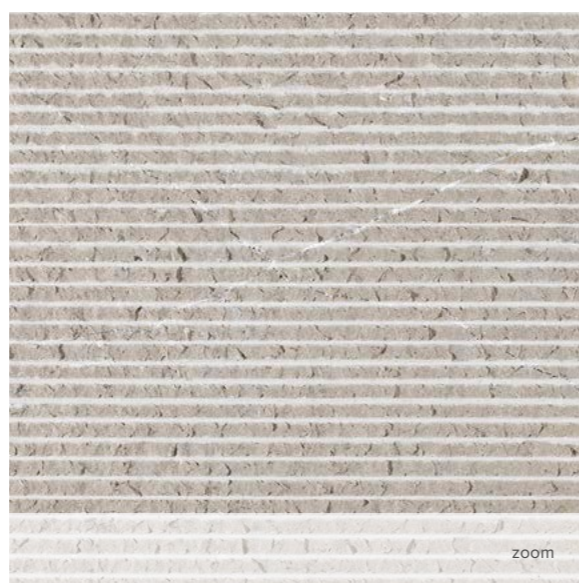

zoom

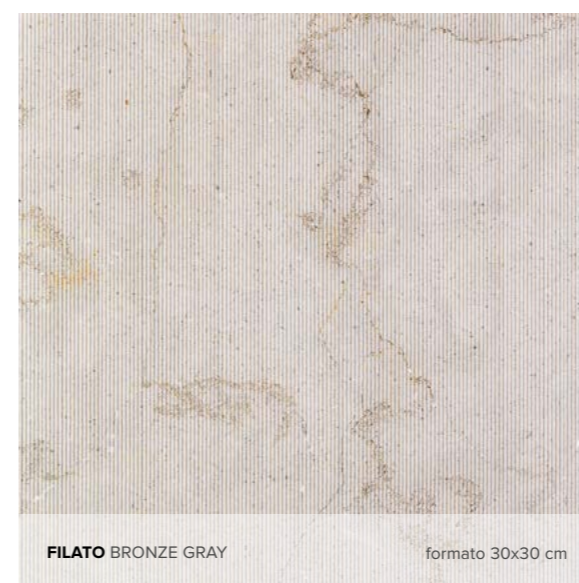

FILATO BRONZE GRAY

formato 30x30 cm



zoom

Le finiture sono disponibili
in tutte le varietà dei materiali
a catalogo

Surfaces are available
in all our marbles



CORTECCIA BRONZE GRAY

Le finiture sono disponibili
in tutte le varietà dei materiali
a catalogo

Surfaces are available
in all our marbles



RIGATO NERO ASSOLUTO

MOSAICI

MOSAICS



BIANCO CARRARA



GRIGIO TUNISI

HEXAGON

Tessere in marmo incollate su rete con fuga di 2 mm

Formato esagonale
diametro 4,8 cm
Peso 40 kg/mq

Disponibile in tutta la gamma dei colori a catalogo

Sheets consisting of mosaic inserted on a fiberglass with 2 mm joints

4,8 cm diameter hexagon
Weight 40 kg/mq

Available in all our marbles



GRIGIO ASH



EBANO

WALL

Tessere in marmo incollate su rete con fuga di 2 mm

Formato
9,8x1,4 + 7,3x1,4 cm
Peso 40 kg/mq

Disponibile in tutta la gamma dei colori a catalogo

Sheets consisting of mosaic tiles inserted on a fiberglass with 2 mm joints

Size 9,8x1,4 + 7,3x1,4 cm
Weight 40 kg/mq

Available in all our marbles



BIANCO PERLINO



EBANO

BRICK

Tessere in marmo incollate su rete con fuga di 2 mm

Formato 4,8x2,3 cm
Peso 40 kg/mq

Disponibile in tutta la gamma dei colori a catalogo

Sheets consisting of mosaic tiles inserted on a fiberglass with 2 mm joints

Size 4,8x2,3 cm
Weight 40 kg/mq

Available in all our marbles



GRIGIO ASH

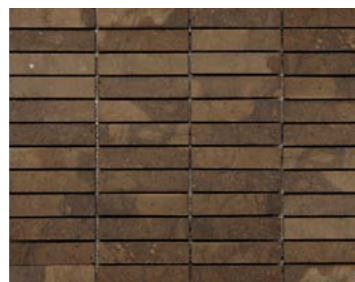

EBANO

RULER

Tessere in marmo incollate su rete con fuga di 2 mm

Formato 9,8x2,3 cm
Peso 40 kg/mq

Disponibile in tutta la gamma dei colori a catalogo

Sheets consisting of mosaic tiles inserted on a fiberglass with 2 mm joints

Size 9,8x2,3 cm
Weight 40 kg/mq

Available in all our marbles



GRIGIO ASH



PIETRA GREY

SHUTTER

Tessere in marmo incollate su rete con fuga di 2 mm

Formato 9,8x1,4 cm
Peso 40 kg/mq

Disponibile in tutta la gamma dei colori a catalogo

Sheets consisting of mosaic tiles inserted on a fiberglass with 2 mm joints

Size 9,8x1,4 cm
Weight 40 kg/mq

Available in all our marbles



PIETRA DI BRERA

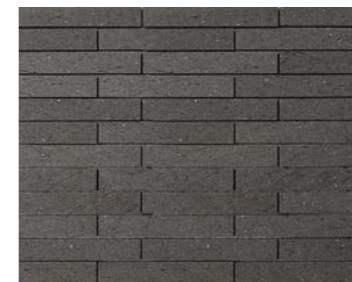

PIETRA LAVICA

STRIP 30

Tessere in marmo incollate su rete con fuga di 2 mm

Formato 14,8x2,3 cm
Peso 40 kg/mq

Disponibile in tutta la gamma dei colori a catalogo

Sheets consisting of mosaic tiles inserted on a fiberglass with 2 mm joints

Size 14,8x2,3 cm
Weight 40 kg/mq

Available in all our marbles



PIETRA DI BRERA



GRIGIO ASH

STRIP 50

Tessere in marmo incollate su rete con fuga di 2 mm

Formato 4,8x2,3 cm
Peso 40 kg/mq

Disponibile in tutta la gamma dei colori a catalogo

Sheets consisting of mosaic tiles inserted on a fiberglass with 2 mm joints

Size 4,8x2,3 cm
Weight 40 kg/mq

Available in all our marbles



PIETRA DI BRERA
E NEW GRANADA BEIGE



GRIGIO ASH E PIETRA GREY

NET

Tessere in marmo incollate su rete con fuga di 2 mm

F.to 9,8x1,4 + 7,3x1,4 cm
Peso 40 kg/mq

Disponibile in tutta la gamma dei colori a catalogo

Sheets consisting of mosaic tiles inserted on a fiberglass with 2 mm joints

Size 9,8x1,4 + 7,3x1,4 cm
Weight 40 kg/mq

Available in all our marbles

FORMATI E DIMENSIONI FORMATS AND SIZES

QUADRATO SQUARE



20x20x1,4 cm
30x30x1,4 cm
40x40x1,9/1⁺ cm
50x50x2 cm
60x60x2 cm
80x80x2 cm

PENTAGONO PENTAGON

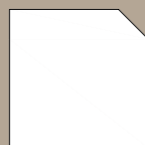

30x30x1,4 cm
40x40x1,9/1⁺ cm

ESAGONO HEXAGON



30x30x1,4 cm
40x40x1,9/1⁺ cm

OTTAGONO OCTAGON

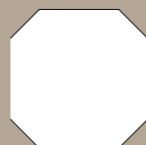

30x30x1,4 cm
40x40x1,9/1⁺ cm

TRIANGOLO TRIANGLE

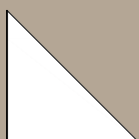

9,8x9,8x1,4 cm
30x30x1,4 cm

RETTANGOLO RECTANGLE

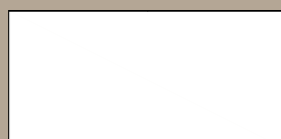

30x60x1,4 cm
40x80x1,9/1⁺ cm
30x90x1,4 cm
110x30x1,4 cm
120x60x2 cm

TOZZETTO SMALL TILE



5x5x1,4 cm
7x7x1,4 cm
9,8x9,8x1,4 cm
14,8x14,8x1,4 cm

FORMATI A CORRERE FREE-LENGTH FORMATS

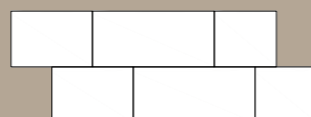

30x1,4 cm correre
40x1,9 cm correre

"OPUS QUADRATA"

Modulo 1,08 m² / 1,08 m² module

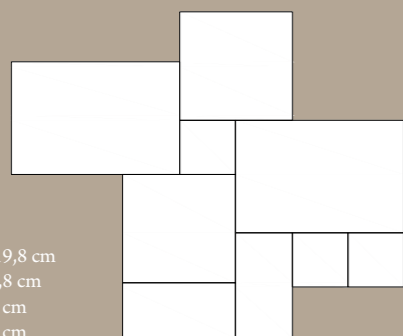

3 pz. 19,8x19,8 cm
2 pz. 40x19,8 cm
2 pz. 40x40 cm
2 pz. 60x40 cm

ZOCCOLINO SKIRTING

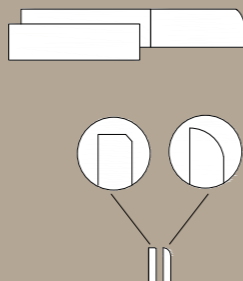

7x1,5 cm correre
30x7x1,4 cm correre

LOSANGA LOSANGE



30x7x1,4 cm
40x10x1,9 cm

TORELLI TORUSES



GUIDA ALLA POSA GUIDE TO LAYING

Pibamarmi realizza i suoi prodotti con tecnologie e procedimenti rispettosi dell'ambiente. La particolare finitura patinata che i marmi assumono, esalta l'unicità e la bellezza della pietra naturale. Al termine dei processi produttivi i marmi vengono sottoposti ad un trattamento protettivo oleo-idrorepellente.

La posa

La posa di pavimenti e rivestimenti è un'operazione che va eseguita con la massima attenzione. Per raggiungere un risultato ottimale si consiglia di posare a colla. La posa a sabbia e cemento è sconsigliata.

Preparazione del collante

Le colle da noi consigliate sono: Granirapid (Mapei), Keraflex (Mapei), H40 Flex (Kerakoll), H40 Marmorex (Kerakoll). In caso di marmo con la superficie inferiore resinata è necessario l'uso di una colla bicomponente tipo Superflex (Kerakoll) o Keralastic (Mapei).

Installazione e stuccatura

La fuga, di misura ottimale tra i 2 e i 3 millimetri, va eseguita con distanziatori a crocetta.

Le difficoltà maggiori che si possono incontrare sopraggiungono generalmente nella fase di stuccatura della fuga tra le piastrelle. Si consiglia di bagnare abbondantemente la superficie, soprattutto nel caso di limestones, procedendo successivamente al trattamento di poca superficie per volta, in modo tale da riuscire a rimuovere perfettamente, con una spugna, i residui di stucco rimasti sui bordi e sulle venature delle piastrelle. Il tipo di stucco consigliato è il Keracolor/ Ultracolor della Mapei, da scegliere in una versione che sia il più possibile in tinta con il materiale lapideo.

Consigli pratici

- Per evitare sbeccature sui bordi si sconsiglia di effettuare tagli delle coste a 45°.
- Per il taglio delle lastre si consiglia l'utilizzo di un clipper a disco diamantato con raffreddamento ad acqua.
- Non effettuare fori con trapano a percussione; utilizzare esclusivamente utensili da marmo con trapano a sola rotazione.
- L'apertura degli imballaggi, con la relativa rimozione del materiale dalle casse, deve essere fatta con la maggior cura possibile per evitare lesioni sui bordi delle lastre.
- Lo scarico delle casse di lastre dal mezzo di trasporto deve essere effettuato con gru munite di apposite forche e non con cinghie.
- Nel caso in cui la fugatura non sia stata in origine pulita correttamente e presenti residui di stucco in eccesso, far eseguire a una ditta specializzata il lavaggio della superficie con detergente a base acida.
- Non esporre i manufatti in marmo ai raggi solari.

Pibamarmi creates its products with environment-friendly technologies and procedures. Its marbles are characterized by a coated finishing that exalts uniqueness and beauty of the natural stone. At the end of the productive process marbles are treated with oil – and water – repellent protection.

Laying

The laying of floors and claddings is an operation to be carried out with extreme care. In order to obtain the best result we recommend using adhesives. Laying with sand or cement is not advisable.

Preparation of the adhesive

The adhesives we recommend are: Granirapid (Mapei), Keraflex (Mapei), H40 Flex (Kerakoll), H40 Marmorex (Kerakoll).

In case of marble with resin-covered lower surface it's necessary to use two-component adhesive Superflex (Kerakoll) or Keralastic (Mapei).

Installation and grouting

Spacings between tiles should measure 2-3 millimetres and be defined using crosspiece spacers.

The most difficult passage is grouting the spacings. Wet abundantly the surface, especially limestones, then work on a small surface area at a time, in order to perfectly remove, with a suitable sponge, the residue of grout left on the edges and on the veins of the tiles.

The recommended grout is Mapei Keracolor/ Ultracolor, to be chosen in a colour as similar as possible to the marble one.

Practical information

- It is advisable to cut the marble at an angle of 45 degrees to avoid any chipping.
- Marbles should be cut exclusively with a Clipper with diamond wheel and water cooling. Do not use a tile-cutter designed for ceramic floors.
- Drilling holes on wall cladding should be avoided.
- If the marble is dirty due to organic material (e.g. dark wood sawdust or similar), this can be removed using highly concentrated hydrogen peroxide, which will penetrate the marble without damaging it and bleach the staining agent.
- Unpacking the material must be carried out with maximum care to prevent accidental chipping of the plates.
- Unloading the boxes from the truck must be done with cranes equipped with suitable forks.
- If grouting was not correctly cleaned and excessive residue of grout is present, instruct a specialist firm to clean the surfaces with an acid-based detergent.
- Keep away the marble elements from solar light.

PULIZIA E MANUTENZIONE

CLEANING AND MAINTENANCE

INTERNI

Trattamento antimacchia

Effettuare un lavaggio della superficie utilizzando il prodotto detergente Fila Cleaner o Fila PS87. A superficie pulita e asciutta stendere il protettivo antimacchia Fila W68 o Fila Fob per un effetto naturale, usare invece Fila Stoneplus per un effetto ravvivante.
Cera di finitura: Fila Matt o Fila Satin.

Manutenzione e pulizia ordinaria

Per la normale pulizia e manutenzione usare Fila Cleaner come detergente e, al bisogno, rinnovare la ceratura con Fila Matt o Fila Satin.

Manutenzione straordinaria

Usare Fila PS87 come decerante-sgrassante.

INTERNI DOCCIA E ZONE BAGNATE

Trattamento antimacchia

Effettuare un lavaggio della superficie utilizzando il prodotto detergente Fila Cleaner o Fila PS87. A superficie pulita e asciutta stendere il protettivo antimacchia Fila Hydrorep + Fila Fob per un effetto naturale oppure Fila Stone Plus per un effetto ravvivante.
N.B. Non usare cere di finitura sulle superfici a contatto con l'acqua.

Manutenzione e pulizia ordinaria

Per la normale pulizia e manutenzione usare Fila Cleaner come detergente.

Manutenzione straordinaria

Usare Fila PS87 come decerante-sgrassante.

PIANI LAVABO E MANUFATTI

Questi prodotti vengono forniti già trattati dall'azienda, per la manutenzione e pulizia consigliamo Fila Refresh, detergente neutro che rinnova anche la protezione antimacchia. Oltre al trattamento standard, è disponibile anche il trattamento permanente Acid Shield.

Per l'utilizzo di tutti i prodotti Fila seguire le indicazioni dell'azienda su www.filachim.com

INTERIORS

Stain-resistant treatment

Wash the surface using Fila Cleaner or Fila PS87 detergents. Once the surface is dry, apply the stain-proofing protective agent Fila W68 or Fila Fob to obtain a natural result. Use Fila Stoneplus to get an enhancing effect.
Finishing waxes: Fila Matt or Fila Satin.

Ordinary cleaning and maintenance

For normal cleaning and maintenance use Fila Cleaner detergent and, if necessary, Fila Matt or Fila Satin to renovate waxing.

Extraordinary maintenance

Use Fila PS87 as degreasing cleaner and wax remover.

SHOWER INTERIORS AND WET SURFACES

Stain-resistant treatment

Wash the surface using Fila Cleaner or Fila PS87 detergents. Once the surface is dry, apply the stain-proofing protective agent Fila Hydrorep and Fila Fob to obtain a natural result. Use Fila Stoneplus to get an enhancing effect.
Please note: do not use finishing waxes on surfaces in contact with water.

Ordinary cleaning and maintenance

For normal cleaning and maintenance use Fila Cleaner detergent.

Extraordinary maintenance

Use Fila PS87 as degreasing cleaner and wax remover.

BASINS AND MANUFACTURES

When provided by the firm, these products are already treated: for cleaning and maintenance we recommend Fila Refresh, a neuter detergent that also renovates the stain-proofing protection. Beside the standard protection, it is also available the permanent protection Acid Shield.

Visit www.fliachim.com for information about using all the Fila products.

CREDITS

Art direction
Davide Turrini

Progetto grafico
Studio Variabile

Fotografie
Giovanni De Sandre
Raffaello Galiotto
Davide Galli
Peppe Maisto
Alberto Parise
Giuliano Rancan

Disegni collezioni
Elena Tonin

Stampato in Italia
da Grafiche Antiga spa
che, attraverso l'uso
di energie rinnovabili,
dimostra il suo impegno
costante per la tutela
dell'ambiente.

Pibamarmi

Pibamarmi srl

Sede commerciale e showroom

via Chiampo, 78
36071 Arzignano (VI)
tel. +39 0444 688775
fax. +39 0444 480977
info@pibamarmi.it

Sede legale e laboratorio

via Arzignano, 43
36072 Chiampo (VI) Italy

Laboratorio

via Fabbrica, 8
36072 Chiampo (VI) Italy

tel. +39 0444 688775
fax +39 0444 480977

www.pibamarmi.it

